

# Automotive Service – Study Guide

©2012 Melior, Inc.

---

## Table of Contents

CAREERS IN THE AUTOMOTIVE FIELD.....	8
The Automotive Technology Career .....	8
Opportunities in the Automotive Field .....	8
Training and Certification.....	9
Job Prospects in the Automotive Technology Field.....	10
Common Methods Used to Pay Automotive Technicians .....	11
Other Facts About Working as an Automotive Technician.....	11
SOLVENTS, SOAPS, AND CLEANING SOLUTIONS.....	12
General Rules for Using Chemicals .....	12
Types and Uses of Solvents.....	12
Parts-washing solvent (petroleum-based).....	12
Parts-washing solvent (aqueous based) .....	12
Choke and throttle body cleaner .....	13
Brake cleaner .....	13
Gasket remover.....	13
Digestive-type carburetor cleaner .....	14
Gasoline .....	15
Types and Uses of Soaps and Cleaning Solutions .....	15
Cleaning shop floors.....	15
Specialty cleaning agents.....	16
LUBRICANTS AND SPECIALTY CHEMICALS .....	17
General Rules for Using Oils.....	17
Types and Uses of Oils .....	17
Light or penetrating oils.....	17
Standard and heavy oils .....	17
Hydraulic fluids .....	18
General Rules for Working With Grease.....	18
Types and Uses of Greases .....	19

Types and Uses of Specialty Additives .....	19
Types and Uses of Specialty Chemicals.....	20
Locking and antiseize compounds .....	21
TYPES OF WRENCHES.....	22
Metric and U.S. Customary System (USCS) Wrenches.....	22
Common Wrenches .....	23
Socket Wrenches .....	25
Other Wrenches.....	29
TYPES OF SCREWDRIVERS AND PLIERS .....	31
Screwdrivers.....	31
Pliers.....	33
TYPES OF HAMMERS, PUNCHES, AND CHISELS .....	36
Hammers.....	36
Safety .....	37
Punches.....	38
Chisels .....	39
SPECIALTY TOOLS .....	41
Special Cutting Tools.....	41
Electrical System Tools.....	43
Lubrication Specialty Tools .....	47
Miscellaneous Specialty Tools .....	48
FASTENERS .....	49
Common Vehicle Fasteners .....	49
Nuts and bolts in the U.S. Customary System (USCS).....	49
Nuts and bolts in the metric system .....	51
Washers .....	51
Types of screws.....	52
Studs.....	53
Snap rings.....	53
Rivets.....	54
Adhesives .....	54
Cutting Threads, Repairing Threads, and Removing Broken Bolts .....	55

Types of taps .....	55
General procedure for using a tap .....	55
Using a die to cut threads onto a rod .....	56
General procedure for using a die .....	56
Procedures for repairing damaged or stripped threads .....	57
Procedures for removing a bolt that is broken off in a threaded hole because of overtightening....	57
MEASURING TOOLS.....	58
Types and Uses of Common Measuring Tools .....	58
Procedures for the Use and Care of Measuring Tools .....	60
Using an outside micrometer.....	60
Using a dial indicator.....	61
Using a feeler gauge.....	61
Using a dial caliper .....	62
Using Plastigage .....	62
Care of measuring tools .....	62
POWER TOOLS .....	63
Principles of Using Power Tools .....	63
Electric tools.....	63
Pneumatic tools .....	64
Basic designs of pneumatic tools.....	65
Pneumatic couplings .....	65
Cordless tools.....	65
Hydraulic tools .....	65
Power Drills .....	66
Drill bits .....	67
Power Wrenches.....	68
Impact wrench .....	68
Using impact wrenches.....	69
Air ratchet .....	69
Air chisel (air hammer).....	70
Miscellaneous Power Tools.....	71
Heat gun.....	71

Mini die grinder.....	72
Blowgun .....	72
SHOP EQUIPMENT .....	73
Electrical Equipment .....	73
Wheel balancer .....	73
Bench grinder.....	74
Drill press .....	75
Test and service equipment.....	76
Pneumatic Equipment.....	76
Tire machine .....	77
Pneumatic jack.....	78
General maintenance guidelines for pneumatic equipment.....	79
Hydraulic Equipment.....	79
Hydraulic floor jack .....	79
Hydraulic lift.....	80
Hydraulic press.....	80
Engine hoist.....	81
Vehicle Service Information.....	83
Sources.....	83
Formats .....	83
Using the Manufacturer's Service Information.....	84
Locating and Reading the Vehicle Codes .....	85
CUSTOMER SERVICE, WORK ORDERS, AND VEHICLE PREPARATION.....	86
Proper Customer Relation Procedures .....	86
Preparing a Vehicle Before and After Service .....	87
Functions and Components of a Work Order .....	89
Diagnosing a Vehicle Problem .....	90
BRAKE SYSTEM FUNDAMENTALS.....	92
Principles of Friction .....	92
Heat and Brake Linings.....	93
Weight and Speed.....	94
Friction Between Tire and Road.....	95

Service Brakes & Parking Brakes .....	95
Base Brake Components .....	96
Brake Subsystems .....	96
Hydraulic Principles.....	97
Split Hydraulic Systems .....	99
Diagonal Split Hydraulic System.....	99
Front/Rear Split Hydraulic System .....	100
Regenerative Braking .....	100
<b>ELECTRICAL FUNDAMENTALS .....</b>	<b>101</b>
Electrical Properties .....	101
Voltage .....	101
Current .....	101
DC and AC.....	102
Resistance .....	102
Shorts and Opens .....	103
Voltage Drop .....	103
Battery and Starting/Charging System Test Equipment .....	104
<b>AUTOMOTIVE BATTERIES.....</b>	<b>105</b>
Battery Function .....	105
Battery Construction.....	106
Low Maintenance and Maintenance Free Batteries.....	107
Gel Cell and Absorbent Glass Mat (AGM) Batteries .....	108
Electrolyte and Specific Gravity .....	109
Chemical Reactions while Discharging and Charging.....	109
Battery Safety.....	110
Battery Temperature and Efficiency .....	112
Battery Ratings.....	114
Cold Cranking Amps (CCA) .....	114
Cranking Amps (CA) .....	114
Reserve Capacity (RC) .....	114
Ampere-Hour Rating (AH).....	114
<b>BATTERY CHARGE AND TESTING.....</b>	<b>115</b>

How Batteries Lose Power .....	115
Normal Aging .....	115
Overcharging.....	115
Undercharging and the Result: A Sulfated Battery.....	116
Parasitic Loads.....	116
Phantom Drains .....	118
Self-Discharging.....	119
Inoperative or Missing Hold-Down .....	119
Corrosion.....	119
Battery Testing and Service .....	121
Initial Assessment .....	121
Open Circuit Voltage .....	122
Hydrometer Testing .....	123
Built-In Hydrometers .....	123
Conventional Hydrometers.....	124
ENGINE OVERVIEW .....	128
Basic Engine Parts and Operation.....	128
Engine Block.....	128
Cylinders.....	130
Pistons.....	130
Piston Rings.....	131
Connecting Rods .....	131
Crankshaft.....	132
Cylinder Head.....	133
Valve Train .....	134
The Four-Stroke Cycle (Otto Cycle).....	135
Other Engine Designs.....	137
Two-Stroke Cycle Engines .....	137
Diesel Engines .....	141
Rotary Engines .....	143
Engine Classifications .....	144
Number and Arrangement of Cylinders.....	144

Displacement .....	147
Number of Valves and Valve Train Type .....	148
Pushrod Engines.....	149
Fuel Type.....	149
Cooling System Type .....	149

## CAREERS IN THE AUTOMOTIVE FIELD

### The Automotive Technology Career

#### Opportunities in the Automotive Field

According to statistics from the U.S. Department of Labor, over 800,000 people in the United States are employed as automotive service technicians and mechanics. Most are employed in the following businesses:

- Automotive repair and maintenance shops
- Automobile dealers
- Retailers and wholesalers of automotive parts, accessories, and supplies

Others work in the following businesses or organizations:

- Gas stations
- Home and automotive supply stores
- Automotive equipment rental and leasing companies
- Federal, state, and local governments

Over 16% own their own business.



Many job opportunities are available that relate directly and indirectly to the automotive technology field.



Opportunities directly related to automotive technology:

- Automotive technician
- Automotive technician's apprentice
- Repair shop supervisor
- Exhaust and emissions technician
- Tune-up technician
- Service writer
- Mechanical unit repairer
- Technician in automotive manufacturing plants
- Air conditioning technician
- Engine technician
- Diesel technician
- Bus inspector
- Tractor technician
- Parts salvager
- Teacher or trainer

**Note:** Many graduates of automotive technology programs qualify to pursue a career as a teacher or trainer with little or no extra training required for an entry-level position.

Opportunities indirectly related to automotive technology:

- Farm equipment technician
- Aircraft technician
- Office equipment service technician/service representative
- Machinist apprentice
- Air conditioning and heating service apprentice
- Industrial machine maintenance technician
- Small engine technician
- Marine equipment technician
- Motorcycle technician

## **Training and Certification**

Repairing and maintaining today's sophisticated vehicles requires knowledge in many diverse systems and technologically advanced areas. The days of getting a job based on performing automotive repair as a hobby or tinkering in the garage are gone. Most job opportunities require formal training in automotive technology in high school or a postsecondary school or college.

### **Certifying organizations**

As stated on their Web site, the **National Institute for Automotive Service Excellence (ASE)** is a nonprofit organization that aims to "improve the quality of vehicle repair and service through the testing and certification of repair and service professionals."

Automotive technicians can be certified in one or more of the eight areas below.

- Brakes
- Electrical/electrical systems
- Engine performance

- Suspension and steering
- Automatic transmission and transaxle
- Engine repair
- Heating and air conditioning
- Manual drive train and axles

To be certified, technicians must have at least 2 years of experience and pass an ASE written examination. They must retake the exam every 5 years to maintain their certification.

The **National Automotive Technicians Education Foundation (NATEF)**, an arm of ASE, reviews training programs to ensure they are meeting ASE standards and staying up-to-date with the continuously changing automotive technology and repair methods.

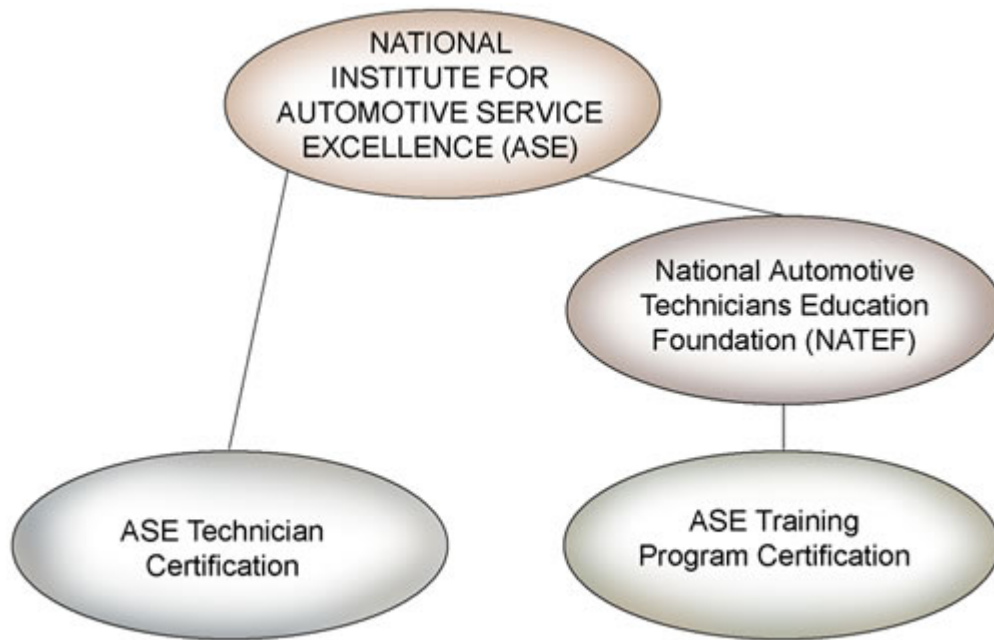

Source: [www.natef.org](http://www.natef.org)

Training programs request the review process on a voluntary basis. If a program passes the review, NATEF recommends it to ASE for certification. Programs must be reviewed again every 5 years to be recertified. In ASE's automobile specialty, training programs can be certified in the eight areas listed previously.

To stay current with changes and advancements in the field, automotive technicians will need to attend training classes throughout their careers. Technicians may receive training at their workplace or may need to attend classes at a technical school or college.

## Job Prospects in the Automotive Technology Field

Prospects are very good for individuals with training and skills in diagnosis, problem solving, electronics, and mathematics. Knowledge in electronics has become crucial because most vehicle concerns involve working with or analyzing the electrical system. According to the Alliance of

Automobile Manufacturers, "electronics now control more than 86% of all systems in a typical vehicle."

Many employers in the industry have reported that there is a shortage of automotive technicians and they have difficulty hiring individuals with education and experience in the areas desired. According to the Occupational Outlook Handbook, published by the U.S. Department of Labor, job opportunities for automotive technicians are expected to increase 9% to 17% through the year 2014. The growth will be due to the increased number of vehicles on the road and the loss of technicians because of retirement or advancement to specialized positions.

Work for automotive technicians is generally steady throughout the year and not very sensitive to changes in economic conditions. Therefore, layoffs are not a big concern.

### **Common Methods Used to Pay Automotive Technicians**

- Hourly – The technician is paid for the time he or she puts in.
- Salary – A salary is a set amount of money, usually 40 hours per week, regardless of the volume of work performed.
- Flat rate – The technician is paid his or her hourly wage multiplied by the time listed for a specific job in a factory flat-rate manual or an aftermarket labor time guide. These guides are sometimes called parts and labor estimating guides. Technicians refer to these as "book hours." The technician is paid this flat rate regardless of the time spent on a job.
- Hourly plus a percentage of labor and parts

### **Other Facts About Working as an Automotive Technician**

Automotive technicians use many different tools and equipment, including those in the following list. Technicians usually purchase their own hand tools, whereas the shop provides the more expensive power tools and equipment.

- Common hand tools
- Power tools
- Machine tools
- Welding and oxyfuel cutting equipment
- Lifts and jacks
- Computers to perform administrative tasks and access service information
- Computerized diagnostic equipment
- Measuring tools
- Test instruments
- Other specialty tools, depending on the automotive technology area

Some shops are unionized, which means that technicians employed there are subject to union rules regarding pay and other issues. For example, the technician may be required to work for 2 years as an apprentice before advancing to the journey level. The union also functions to help employees negotiate with their employers regarding salaries and working conditions.

# SOLVENTS, SOAPS, AND CLEANING SOLUTIONS

## General Rules for Using Chemicals

There are many different types of chemicals used in automotive technology. This lesson will look specifically at some of the more common types of solvents, soaps, and cleaning solutions. First, let's look at some basic rules that apply to working with any type of chemical.

- Follow the manufacturer's recommendations.
- Carefully read the product label for correct uses and hazards.
- Work to prevent spills, damage to the vehicle, or unsafe situations/conditions.
- Properly store chemicals and used rags.
- Use chemicals only for the intended purposes.

**CAUTION:** Consult the instructor before using an unfamiliar product.

## Types and Uses of Solvents

### Parts-washing solvent (petroleum-based)

Petroleum-based **parts-washing solvent** dissolves oil, grease, and varnish from engine components and other parts of the vehicle. It is usually dispensed in a parts-washing tank that filters and recycles the solvent.

This solvent contains **volatile organic compounds (VOCs)** that give off toxic vapors and must be managed as a hazardous waste. Parts-washing solvent is not as flammable as some other solvents, but can burn and does present a fire hazard. Keep electrical devices, sparks, and any hot material away from the parts-washing tank. The solvent tank should be equipped with a safety link, which will melt should the solvent ignite. When the safety link melts, the lid on the washer tank will close and smother the fire.

Parts-washing solvent presents a hazard to the eyes and skin, especially when the solvent is fresh. Breathing solvent vapors is also a health risk. Wear **personal protective equipment (PPE)** when working with the solvent.

**CAUTION:** Some technicians may have a severe allergic reaction to the parts-washing solvent.

Petroleum-based parts-washing solvent can melt some shoe rubber and should never be splashed or poured on the shop floor. If a solvent spill is not immediately wiped up from the floor, it can cause people to slip and fall. Never put units such as electric motors in the solvent tank. Such units may sustain insulation damage; they may also be hard to dry on the inside. To extend the usable life of the solvent and to prevent clogging the tank, remove most of the grease, gasket material, and dirt from parts before washing. Never pour other liquids into the solvent tank.

### Parts-washing solvent (aqueous based)

Aqueous-based **parts-washing solvent** is used for the same purposes as the petroleum-based solvents, but it is typically nonflammable and contains less than 5% VOCs. Besides water, the

ingredients in aqueous-based solvents generally include a detergent, corrosive substance, or alkaline agent and a rust inhibitor. Rather than dissolving grease and solids with chemicals, aqueous solvents use heat, agitation, and detergents to clean automotive parts.

Special cleaning equipment is required that heats the aqueous solvent and sprays it with great force. Spray cabinets, which are totally enclosed, are best for cleaning heavily soiled parts or a large number of parts. Sink-top units are used for more lightly soiled parts or fewer parts.

The life of the solvent can be prolonged by using filters, maintaining the solvent's concentration, and skimming grease from the solution. Aqueous solvent may become hazardous waste through use. Waste disposal professionals must analyze the solution to determine how to dispose of it safely.

### **Choke and throttle body cleaner**

**Choke and throttle body cleaner** is an aerosol product that is more aggressive than parts-washing solvent in cleaning oil, grease, and varnish from carburetor components and other small precision-machined parts. It is a petroleum-based product.

Choke and throttle body cleaner is extremely flammable and presents a dangerous fire hazard. Never spray the cleaner on hot engine parts or around sparks or fire. The cleaner can also damage paint. Do not spray the cleaner near the body of the vehicle or other painted components. Choke and throttle body cleaner can damage eyes and irritate skin. Breathing its vapors is also hazardous. Always wear PPE and spray the cleaner away from the body so that vapors are not inhaled and the cleaner does not contact the skin. Observe the safety warnings on the cleaner can. Do not expose the cleaner can to heat under any circumstances because heat will cause the cleaner can to explode.

### **Brake cleaner**

**Brake cleaner** is an aerosol product that is extremely effective in removing grease and oil from brake drums, rotors, and engine flywheels. Brake cleaner is extremely flammable and presents a severe fire hazard because the cleaner is sprayed from an aerosol can. Brake cleaner can damage paint. Do not spray the cleaner near the body of the vehicle or other painted components. Brake cleaner can damage eyes and irritate skin. Breathing its vapors is also hazardous. Always wear PPE and spray the cleaner away from the body so that vapors are not inhaled and the cleaner does not contact the skin. Observe the safety warnings on the cleaner can. Do not store brake cleaner in a hot area. Do not expose the can to heat under any circumstances because heat will cause the cleaner can to explode.

### **Gasket remover**

**Gasket remover** is an aerosol product that loosens gasket material that may be tightly stuck to engine components with sealers or glue. Gasket remover is extremely flammable and presents a serious fire hazard because the gasket cleaner is sprayed from an aerosol can. Gasket remover can damage paint. Do not spray the remover near the body of the vehicle or other painted components. Gasket remover can damage eyes and irritate skin. Breathing its vapors is also hazardous. Always wear PPE and spray the cleaner away from the body so that vapors are not inhaled and the cleaner does not contact the skin. Observe the safety warnings on the gasket remover can. Do not store

gasket remover in a hot area. Do not expose the can to heat under any circumstances because heat will cause the gasket remover can to explode.

### **Digestive-type carburetor cleaner**

**Digestive-type carburetor cleaner** is an aggressive chemical agent that is usually stored in a 1- or 5-gallon container. The chemical dissolves organic material, leaving only clean metal that is then rinsed with water. Digestive-type carburetor cleaner reacts vigorously with organic material. It presents severe hazards to the eyes and skin. Always wear PPE. Do not splash digestive-type carburetor cleaner.

**CAUTION:** Digestive-type carburetor cleaner will quickly burn skin that it contacts, so flush afflicted areas immediately with water.

To clean parts, gently submerge the basket of parts into the can. When the solvent has finished cleaning, carry the basket with its lid in place to the sink. The basket of clean parts should be placed in the sink and the parts rinsed in a gentle stream of water. Any spills must be cleaned up immediately. Rags or towels used in the cleanup should be discarded.

Because digestive-type cleaner reacts with organic and some nonorganic substances, use it only on metallic parts. Parts made of rubber, fiber, or plastic may be ruined by digestive-type carburetor cleaner. The cleaner may even remove anodized coatings along with paint and varnish. Never use any of these chemicals for purposes other than those listed on the product can or container.

To keep fumes and evaporation to a minimum, add a 1-in layer of water on top of the cleaner and cover the can with a lid. Digestive-type carburetor cleaner is an expensive chemical and should be used only to clean small precision components. Larger components can be cleaned with other solvents.

## Gasoline

Gasoline is intended for use as a fuel, not as a cleaner for automotive parts. Do not use gasoline as a solvent.

**CAUTION:** Never use gasoline or other chemicals for purposes other than those listed on the product can or container. Consult with the instructor before using any solvent or chemical.

Gasoline fumes can cause similar health problems as cleaning solvents and contribute to hydrocarbon emissions. The fumes are also extremely flammable and, if ignited, can cause severe burns or death. Prolonged exposure to liquid gasoline has been shown to cause cancer in laboratory animals. Gasoline additives can leave harmful deposits on important engine components.

## Types and Uses of Soaps and Cleaning Solutions

Soaps and cleaning solutions are water-soluble agents used for cleaning dirt and grease.

Liquid detergent, or dishwashing liquid, is a mild detergent that is convenient to use. Liquid detergent is suitable for washing engine blocks after honing or glaze breaking.

Glass cleaner and windshield washer fluid are available in aerosol, pump spray, or liquid form. The best results are obtained when glass cleaner is used with paper towels rather than shop towels. Shop towels almost always retain grease and leave lint.

**CAUTION:** When filling the windshield washer fluid reservoir in the winter time, read the label on the solution to see if it contains the necessary antifreeze. Freezing can result in a cracked reservoir tank due to expansion.

Hand soaps that are typically used contain an abrasive to help clean ground-in grease. These soaps can cause rawness or cracking of the skin.

**CAUTION:** Never use abrasive hand soaps on vehicle finishes or plastics because scratches can occur.

Hand-cleaning creams are more effective than ordinary hand soaps on grease and dirt. Hand-cleaning creams are also available with abrasives for tough cleaning jobs. These can be used in conjunction with hand soaps. Hand-protecting creams that are applied before work are effective in preventing dirt and grease from staining the hands and arms. Use of ordinary hand soap will remove the hand-protecting cream.

## Cleaning shop floors

According to EPA guidelines, shop workers should keep the shop floor as dry as possible to minimize the amount of wastewater that is generated. Ways to keep the floor dry and clean include the following:

- Keep spills off the floor by using dedicated containers for substances like used oil and antifreeze.
- Clean up spills immediately to prevent workers from slipping in the substance and tracking it to other areas.
- Use rags to clean up small spills and dispose of the soiled rags properly.
- Use absorbent pads or mops to clean large spills and wring the substance from the pads or mops into a dedicated container for recycling or disposal.
- Use floor sweep (granules that absorb liquids) only when cleaning up hazardous waste spills such as gasoline or solvents.
- Sweep the floor with a broom every day to prevent the buildup of dirt and contaminants.
- Do not hose down the floor with water or dump mop water because the contaminants will go into the storm drain or sewer, causing pollution.
- Use water, a mop, and a mild detergent only if necessary after the spill has been removed. Check with local authorities for the proper disposal procedure.

### **Specialty cleaning agents**

There are many specialty cleaning agents that may be used in automotive technology. As with all chemicals, follow the manufacturer's recommendations and only use the cleaners for their intended purpose. Some examples include the following:

- Spot remover
- Bug and tar remover
- Upholstery cleaner
- Carpet cleaner
- Vinyl cleaner and conditioner
- Battery cleaner
- Wire wheel cleaner
- White sidewall cleaner



# LUBRICANTS AND SPECIALTY CHEMICALS

## General Rules for Using Oils

Oil is a petroleum-based or synthetic product that lubricates parts or acts as a hydraulic fluid. When using oil, follow the precautions below.

**CAUTION:** Wear personal protective equipment (PPE) when working with oils.

All types of oils can represent a significant fire hazard. Spontaneous combustion, fire initiated without flame, can and does occur with rags soaked in any type of oil. Oil must be stored in a designated area away from heat, flame, or sparks. Oily rags must be stored in a metal safety container with an airtight lid built for this purpose. Oil can ignite at any temperature above 0° when mixed with pure oxygen. Oil must never be applied to oxyacetylene welding equipment. Immediately use or discard bottles and cans that are leaking oil.

If oil is dripped or spilled on the shop floor, clean it immediately to prevent slipping. Wipe up small spills or drips with a towel. Larger spills may need to be absorbed with sawdust or oil absorbent granules and then swept up and discarded. If necessary, scrub remaining slickness with soap and water. Drain pans help to prevent oil spills.

Avoid prolonged contact with oils. Short-term contact can cause irritation, chapping, or drying of the skin. Long-term contact can cause a variety of skin diseases that includes cancer.

## Types and Uses of Oils

### Light or penetrating oils

**Light or penetrating oils** are aerosol products that include rust-penetrating oil, silicone lubricant, liquid graphite, and belt dressing. Light oils are used to lubricate precision parts because the lubricant gets into tight clearances and does not attract as much dust and dirt as heavier oils. Because they can dissolve some rust, rust-penetrating oils are used to aid in the removal of rusty bolts and fasteners. Liquid graphite dries to a slick, black coating that does not attract any dust or dirt. This makes it desirable for components with tiny moving parts, such as locks. Belt dressing is sprayed on drive belts to prevent slippage and quiet belts that dry out and get noisy.

**CAUTION:** Aerosol cans are pressurized. The can must not be punctured or crushed, even when empty. The can should not be stored near heat or sparks. Never spray these products towards the body.

### Standard and heavy oils

**Standard and heavy oils** are motor oil, automatic transmission fluid, power steering fluid, and gear lube.

**Motor oils** are used in vehicle engines and classified by viscosity or weight (e.g., 10W-30) and a two-letter grade (e.g., SJ and SL). Refer to the manufacturer's recommendation for the correct

viscosity and service classification for the vehicle being serviced. Refer to the vehicle service information for the proper interval for changing the motor oil.

**Automatic transmission fluid (ATF)** is available in three main types: Type F, Dexron III, and Mercon V. ATF is used in all automatic transmissions and some manual-shift, front-wheel-drive transaxles. Some vehicle manufacturers recommend using only their products that include specific additives. Refer to the manufacturer's recommendation when selecting and using ATF.

**Power steering fluid** is similar to ATF. Refer to the manufacturer's recommendation when selecting and using power steering fluid.

**Gear lube** is thicker than motor oil or ATF and provides superior lubrication between the large and highly stressed gears of manual gear boxes and differentials.

### Hydraulic fluids

**Hydraulic fluids** include hydraulic jack oil and brake fluid.

**Hydraulic jack oil** is used in shop equipment that has a hydraulic cylinder, such as jacks, engine hoists, lift racks, and forklifts.

**CAUTION:** Do not add hydraulic jack oil to shop equipment without the permission and supervision of the instructor.

**Brake fluid** is added to the master cylinder reservoir and clutch master cylinder in a hydraulic clutch system. In America, brake fluids must be rated at DOT-3 (Department of Transportation Specification #3) or DOT-4. Using the incorrect brake fluid can result in brake fade, the deterioration of rubber seals, or complete brake failure.

Most hydraulic fluids, especially brake fluid, attack and dissolve paint. Cover fenders when adding brake fluid. Thoroughly wash hands immediately after contact with brake fluid.

**Note:** If you suspect that brake fluid has contacted a painted surface, immediately wash that surface with soap and water.

Hydraulic fluids, especially brake fluid, must be capped tightly to prevent dirt and moisture from contaminating the fluid. Small amounts of moisture can turn to steam when brake fluid becomes hot during brake application. The steam reduces the effectiveness of the brakes. Hydraulic fluids must be stored in a designated area away from heat, flame, or sparks. Never substitute other types of oil for hydraulic oil. Nonhydraulic oil may harm rubber seals or fail under the heat generated by the brake system.

### General Rules for Working With Grease

Grease is used when a lubricant must stay on parts for a long period of time and endure high pressure. When working with grease, follow the precautions below.

**CAUTION:** Wear PPE when working with greases.

Greasy rags are subject to spontaneous combustion. Greasy rags must be stored in a metal safety container with an airtight lid built for this purpose. Grease products must be stored in a designated area away from heat, flame, or sparks. Wipe up grease spills and clean the area immediately with soap and water. Avoid prolonged contact with greases. Short-term contact can cause skin irritation, chapping, or drying of the skin. Long-term contact can cause a variety of skin diseases that includes cancer.

## Types and Uses of Greases

**Multipurpose grease** is suitable for lubricating such items as steering linkage components and wheel bearings. Multipurpose grease can also be used as an assembly glue when packing bearings into a manual-shift transmission. Read the information on the lubrication label before using multipurpose grease to be sure that it is recommended for the planned application.

**Wheel bearing grease** is suitable for steering linkage components as well as wheel bearings. If packing wheel bearings in a disc brake or high heat application, use an extreme-pressure (EP) wheel bearing grease compatible with the disc brakes.

**Brake grease** is applied in small amounts to the backing plate on vehicles equipped with drum brakes.

**Cam lubricant** is sometimes included with a new camshaft. The lubricant can help with breaking in the camshaft.

**White lithium grease** is a general-purpose lubricant available in a tube or aerosol can. Uses of white lithium grease include hood hinges, door hinges, cables, linkage, and shop equipment maintenance.

**Stick lubricants** are used on door strikers because they do not stain clothes.

Some light-colored greases, such as white lithium grease, are not compatible with ATF and should not be used as an assembly glue or as a prelude for internal transmission parts.

**CAUTION:** If noncompatible grease is used during automatic transmission assembly, components in the valve body of the transmission can become stuck, resulting in shifting problems.

**Dielectric grease**, available in a tube, is used to seal electrical connections to prevent voltage leakage and keep out dirt, corrosion, and moisture.

**Brake system silicone compound** is a greaselike lubricant that comes in a tube. It is used to lubricate sliders, rubber parts, or plastic parts on brake systems.

## Types and Uses of Specialty Additives

**Specialty additives** include oil treatment, gas treatment, transmission conditioner, and starting ether. Refer to the container label for hazard warnings and handling procedures.

**CAUTION:** Wear PPE when working with specialty additives.

**Oil treatments** are used to raise motor oil viscosity or to free sticking valves or lifters. Raising the motor oil viscosity can extend engine life by increasing oil pressure.

**Note:** Adding too much oil treatment can result in poor lubricating properties or oil that exceeds the proper viscosity, especially in cold weather.

**Gas treatment** is used to help reduce moisture in gasoline and eliminate buildup of carbon, gum, and varnish in fuel lines. Gas treatment usually contains alcohol. Excessive amounts of methanol can destroy rubber carburetor or fuel system components and damage the lining of the fuel tank.

**Transmission conditioner** is added to automatic transmission fluid to prolong the life of the fluid and improve the shifting performance of worn transmissions.

**Starting ether** is sometimes used to start an engine in extreme cold. The directions for using starting ether must be followed carefully.

**CAUTION:** Starting ether is extremely flammable and can create an explosion if the engine backfires.

## Types and Uses of Specialty Chemicals

There are numerous **specialty chemicals** used in automotive technology. Common specialty chemicals include sealers, locking and antiseize compound, and adhesives.

**CAUTION:** Wear PPE when working with specialty chemicals.

### Sealers

The two types of sealers are hardening and nonhardening. **Hardening sealers** form a hard seal between components. They are used to seal permanent assemblies and to fill gaps in irregular surfaces. **Nonhardening sealers** remain pliable. They are used in areas that are exposed to vibration, expansion, and contraction.

**Room temperature vulcanizing sealer RTV**, typically available in a tube, is a special rubber that sets up at room temperature and forms a seal between components. RTV is used instead of a rubber or fiber gasket. It is aerobic, which means it cures when exposed to air.

**Note:** Some RTVs cannot be used on engines in vehicles equipped with components such as oxygen sensors or automatic transmissions.

**Gasket sealers**, applied with a brush or from a tube, help to ensure a good seal between gaskets and irregular surfaces. These sealers are anaerobic, which means they will cure only in the absence of air.

**Thread sealant** is used to seal threads and bolts that are exposed to liquids, usually either lubricating oil or coolant.

## **Locking and antiseize compounds**

**Locking compounds** prevent a fastener from loosening by acting as a lock washer. Locking compounds have various strengths that range from "wrench removal" to "permanently bonded."

**Antiseize compounds** prevent threaded fasteners from becoming permanently bonded to another component and are used when the fastener is made of a different type of metal from the component to which it is attached.

## **Adhesives**

Two common adhesives are weather strip and gasket adhesive and rearview mirror adhesive. **Weather strip and gasket adhesive** is used to glue gaskets to metal and weather strips to the vehicle's doors and trunk. **Rearview mirror adhesive** is used to glue inside rearview mirrors to the windshield.

## TYPES OF WRENCHES

### Metric and U.S. Customary System (USCS) Wrenches

All technicians should have a set of both metric and USCS (also called SAE) wrenches for loosening and tightening bolts and nuts.

**Metric wrenches** are sized per the measurement in millimeters (mm) of the jaw opening, from face to face. The jaw size is actually a little larger than the bolt or nut of the same size to allow the jaw to fit around the bolt or nut.

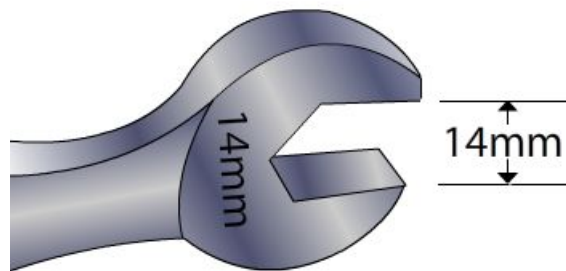

**USCS wrenches** are sized per the measurement in fractions of an inch of the jaw opening, from face to face. The jaw size is actually a little larger than the bolt or nut of the same size to allow the jaw to fit around the bolt or nut.

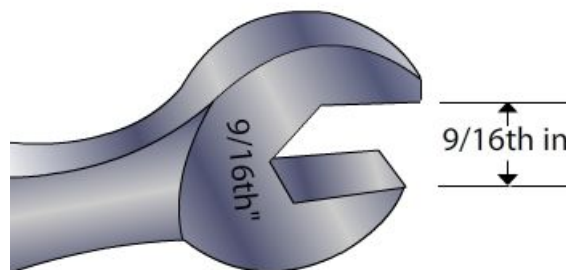

Metric and USCS wrenches are not interchangeable. For example, if removing a 14-mm nut, a 9/16-in wrench is close in size but is not the proper size to effectively remove the nut. The 9/16-in wrench may slip and round off the sides of the nut. A 14-mm wrench should be used.

## Common Wrenches

The **open-end wrench** turns nuts and bolts that have already been loosened. If too much torque or turning action is applied, it can round off the corners of nuts or bolts. The ends of the wrench are set at a 15° angle to reduce the distance the wrench is moved to grip the next side of the hex head.



The **box wrench** completely encircles the nut or bolt to grip all the corners, which allows considerably more torque to be applied without stripping the nut or bolt. This wrench is particularly useful for loosening tight bolts and nuts. More time is required to turn loose bolts with the box wrench.



The **combination-end wrench** is a combination open-end and box wrench. It is a favorite of technicians because of its multiple uses.



A **tubing wrench**, or **flare nut wrench**, has ends with a portion of one side cut away so that the wrench may be slipped over a steel line. Each end partially encircles the hex head of a nut or bolt. Steel line fittings are usually brass and require this type of wrench to loosen a tight fitting without causing damage.



**Note:** In addition to the tubing wrench, an open-end wrench is used to firmly hold the fitting while attaching it to the steel line. Do not allow the steel line to become twisted.

### **Maintenance**

- Wrenches should be kept free of dirt and grease and stored in a dry place to prevent rust.
- Wrenches with distorted jaws should be discarded.

### **Safety**

- Always use the proper size wrench. Do not use metric wrenches on USCS bolts or vice versa.
- Do not use a wrench as a hammer or pry bar.



## Socket Wrenches

This wrench is so named because it has a cylindrical socket (in the size of the bolt) that fits down over the bolt, much like a box-end wrench. The **socket wrench** is the preferred tool of most technicians when they work with nuts and bolts. Socket wrenches can be used in places that are inaccessible to common wrenches and are faster at removing bolts.

The two basic parts of a socket wrench are the socket and bar or handle. Sockets come in metric and USCS sizes and are sized according to the size of the bolt head they fit and the size of the bar they take. They are available in four point types: 4 point, 8 point, 6 point, and 12 point, with the 6-point and 12-point sockets being the most commonly used.

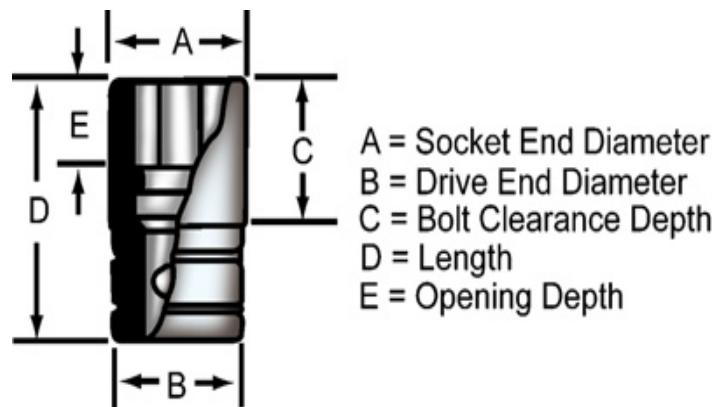
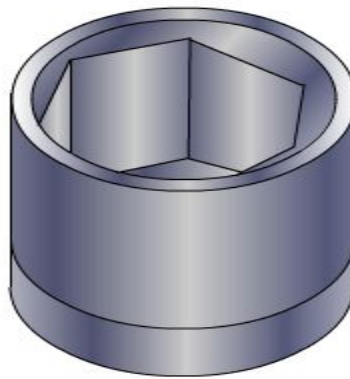

- A shallow 12-point socket is used for turning hexagonal bolt heads in tight places because it offers twice as many starting positions.
- A shallow 6-point socket is used for turning hexagonal bolt heads because it offers better grip and less chance of rounding off the bolt head when excess torque is used.
- A deep-well 12-point socket is used to turn nuts when a bolt or stud protrudes through the nut enough to prohibit the use of the shallow socket.
- A deep-well 6-point socket is used in the same situation as described above. It is particularly useful when there is a risk of rounding off tight nuts.

**Swivel sockets**, or **universal sockets**, have a universal joint built into the socket drive end that allows bolts and nuts to be turned when it is not possible to get straight onto the head.

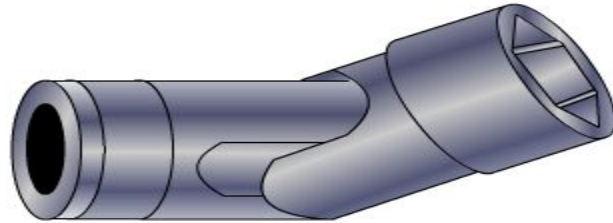

**Impact sockets** are designed to withstand the great torque and impact delivered by air impact tools. An impact socket has thicker construction than a standard socket. Note that impact sockets that are used for pneumatic tools are black and not chrome - using a chrome socket with a pneumatic tool might damage the tool and could potentially be unsafe for the mechanic.

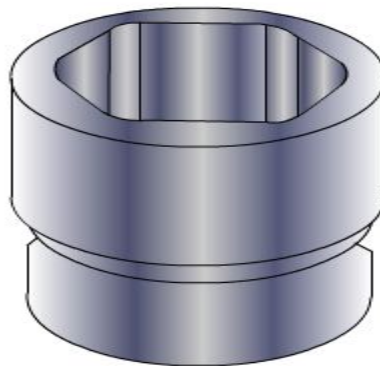

**CAUTION:** Do not use standard sockets on air impact guns because the socket may shatter.

Bars and handles are used to turn the sockets. The drive end is square and available in 1/4-in, 3/8-in, 1/2-in, and 3/4-in sizes.

**Note:** The 3/4-in size is used for large, heavy-duty bolts that are found in trucks. The 1/2-in size is used on large automotive bolts. The 3/8-in size is the most commonly used by technicians. For very small work, the 1/4-in size is used because of its compactness.

The **breaker bar** is a sturdy handle that is used when great torque is required to loosen bolts and nuts. The end of the breaker bar can swing to allow clearance.

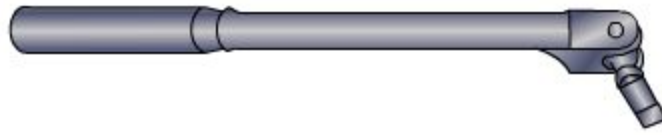

**Note:** The length of the handle on the breaker bar provides superior leverage for tight nuts and bolts.

The ratchet is the most commonly used handle for turning sockets. By rotating back and forth, the ratchet turns nuts and bolts in areas of limited access without being removed after each partial turn.

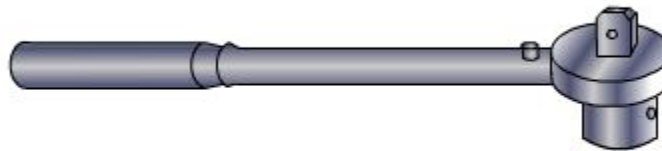

The ratchet is not intended for use under extreme torque because the teeth on the ratchet mechanism may strip. Some ratchets have heads that swivel, which allows clearance while turning.

**Extension bars** aid in reaching recessed bolts and nuts by extending the ratchet drive end. Common extension lengths include 3 in, 6 in, and 12 in. Many other lengths are also available.



**Speed handles** and T-handles are occasionally used to speed assembly. One advantage of these handles is they do not place side stress on the extension and socket. These handles are not used for the final tightening.

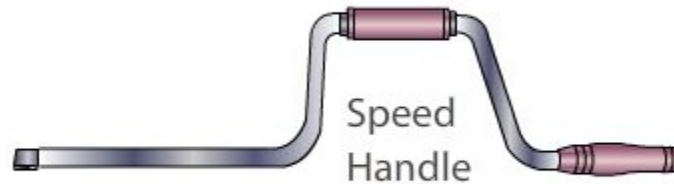

A **torque wrench** is a special handle that indicates the amount of twisting force (torque) that is being applied in tightening a bolt.



A torque wrench is necessary when the torque of bolts must meet manufacturer's specifications. Some models have a scale or dial to indicate torque. Others click or release momentarily when the preset torque is reached. Most recently, electronic versions are available that have easily programmable and accessible torque settings and indicate torque by vibrating, producing an audible signal, and providing a digital display.

**Note:** Specifications for the torque of bolts are extremely important. If too much torque is applied, the surfaces being joined or the bolt/nut will be damaged. If too little torque is applied, the bolt may work loose.

Occasionally, the technician must use a **socket adapter** on a socket to ease bolt removal.

**Note:** The **torque capacity** of the socket and ratchet must be considered so that the tool is not damaged or broken.

A size adapter allows the technician to use a different drive size socket on the ratchet or torque wrench.

**Note:** Care must be exercised when adapting large breaker bars down to smaller drive sockets because the torque capacity of the small socket may be exceeded.

A universal adapter operates best when a socket has limited access that prevents the ratchet and extension from engaging straight onto the socket. These adapters cannot withstand great amounts of torque.

### Maintenance

- Sockets and handles should be kept free of dirt and grease and stored in a dry place to avoid rust.
- Ratchet handles can become worn and should be reconditioned if the ratchet starts to slip.

### Safety

- Ratchet handles can turn both counterclockwise and clockwise and the lever that switches the direction should be firmly and fully placed into its proper position.

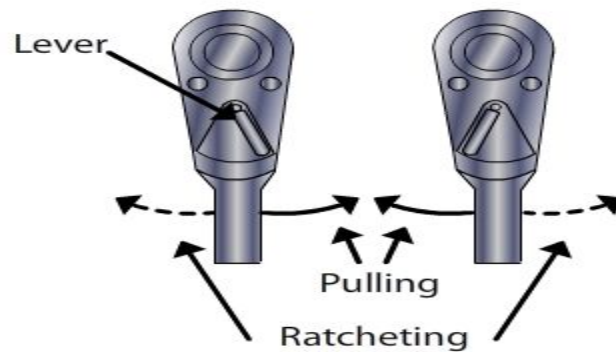

- Do not use a ratchet handle as a hammer or pry bar.
- The exact size socket must always be used. Damaged sockets should be discarded, because they can slip off a bolt.
- When using a socket on a damaged bolt head, be especially careful so the wrench does not slip off and cause an injury to the knuckle or hand.
- Always be sure the socket is completely over the bolt head. If the bolt head is so damaged that the socket cannot fit completely over the head, use another method of removal.

### Other Wrenches

An **Allen wrench** is used on hex head fasteners, which contain a cavity with six sides. A torx wrench is used on torx bolts, which contain a cavity of six rounded points. This design reduces the risk of stripping or disengaging the threads of small fasteners.

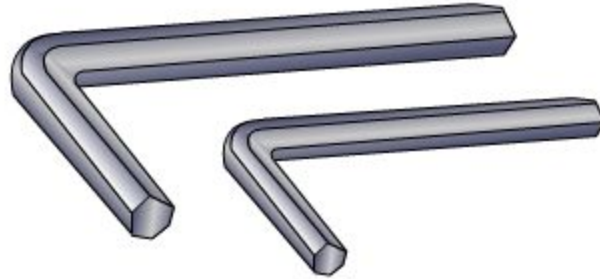

Allen Wrenches

An **adjustable wrench** has a screw that allows the jaw to adjust to different sizes. Under normal circumstances, technicians do not use an adjustable wrench for turning nuts and bolts. It has the disadvantage of not gripping as solidly as box-end wrenches, and unless properly adjusted and in good condition, may not grip as solidly as open-end wrenches. An adjustable wrench may be used if the technician does not have immediate access to the proper wrench and if torque requirements are not too high.

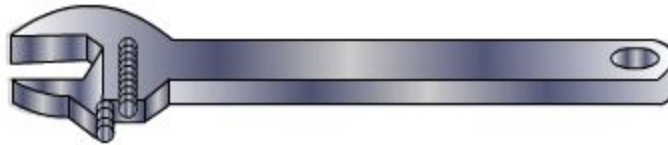

**Standard wrenches** cannot be used on pipes because of the round shape of pipes. The pipe wrench has teeth that dig in as the wrench turns the pipe. The risk of scarring the pipe can be reduced by placing a leather strap between the pipe and the wrench teeth.



## TYPES OF SCREWDRIVERS AND PLIERS

### Screwdrivers

The **standard screwdriver** has a straight blade for turning screws with a slot that is the same width and length as the screwdriver blade.

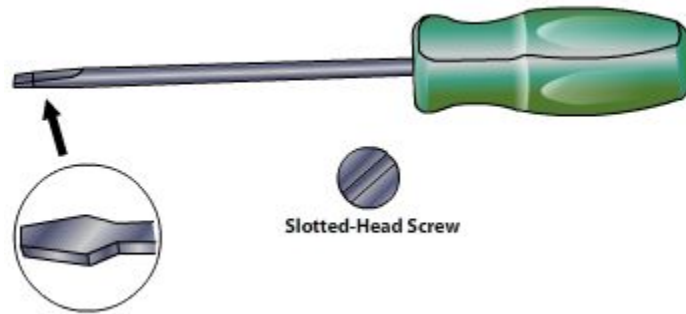

**CAUTION:** The standard screwdriver is not intended for use as a pry bar, chisel, or gasket scraper. These misuses of the screwdriver can damage the tool and injure the technician.

The **Phillips screwdriver** fits the crossed slot of a Phillips screw. One advantage this screwdriver has over the standard one is when it is inserted in the slot, it is self-centering. Phillips screwdrivers are available in various tip sizes (e.g., #0, #1, #2, #3, #4) with the lower number being the smallest. A technician should not attempt to use a standard screwdriver to turn a Phillips screw. A good deal of pressure must be applied when using a Phillips screwdriver or the tip may disengage the slot, damaging the screw or the tool. If the slot of a Phillips screw is stripped, it will have to be drilled out.

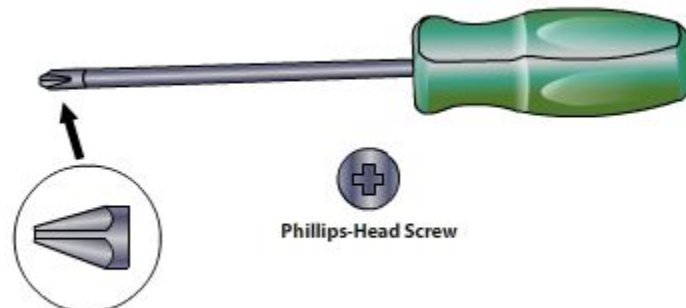

The **Pozidriv screwdriver** is similar to the Phillips in that it is used on a cross-slotted screw. However, the Pozidriv screwdriver and screw head have four additional points of contact.

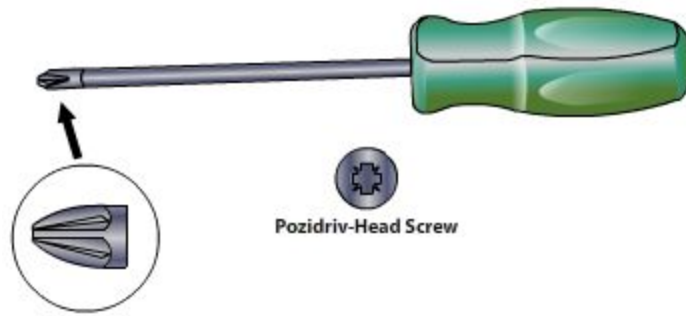

More torque can be applied with the Pozidriv screwdriver because the blade will not slip out of the screw head as easily as the Phillips screwdriver will. Although not recommended because of improper fit, a Phillips screwdriver will turn a Pozidriv screw. A Pozidriv screwdriver, however, will not turn a Phillips screw.

The **torx screwdriver** has a 6-point tip that is used on torx-head screws.

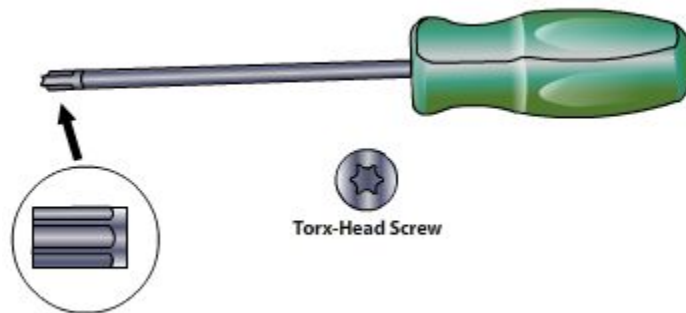

**Nut drivers** have a handle and shaft like a screwdriver but have a socket at the end of the shaft that is not removable. Because nut drivers can be operated with greater speed than socket wrenches, they are ideal for loosening and tightening the small nuts and bolts found on vehicles.





## Maintenance

- Keep screwdrivers free of dirt and grease and store them in a dry place to prevent rust.
- Keep the heads in good condition and free from nicks.

## Safety

- The right size screwdriver should be used for each job. The screwdriver should be the right length for access to leverage. The head of the screwdriver should match the head of the screw (both type and size of the screw).
- Do not try to use another tool, such as locking pliers, to grab the handle of the screwdriver and get more leverage. If it cannot be turned by hand, another tool is needed.
- Use screwdrivers with insulated handles to prevent electric shock.
- Do not use a screwdriver as a punch or chisel.

## Pliers

Standard slip-joint pliers are one of the most common types of pliers used by technicians. These grip irregular parts and hold work during drilling.

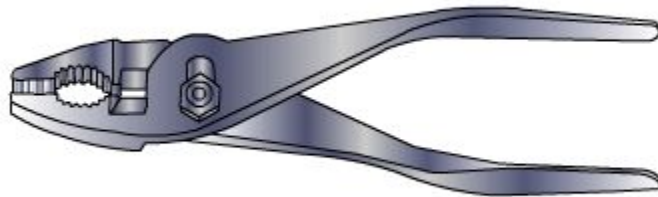

Locking pliers are very similar to standard slip-joint pliers. By turning a knob and then clamping the handles in place, the locking pliers hold work securely.

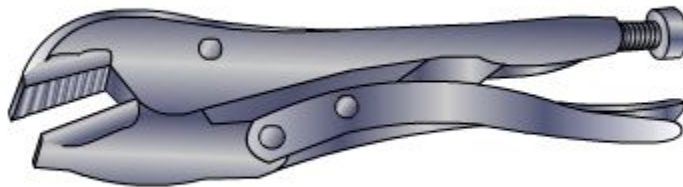

**CAUTION:** When clamping or removing locking pliers, keep a proper grip on the handles. The handles snap together and snap apart with considerable force.

Adjustable-joint pliers have a long slot with a wide variety of adjustment positions. The offset jaws of the adjustable-joint pliers offer a reach advantage.

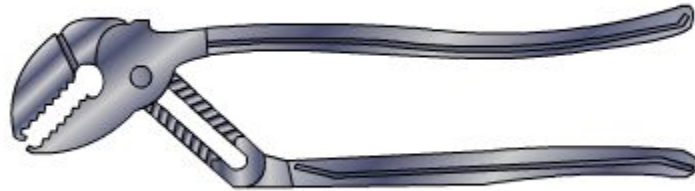

Long-nose pliers, or needle-nose pliers, are useful for gripping tiny pins and parts during the service of carburetors and other small assemblies.

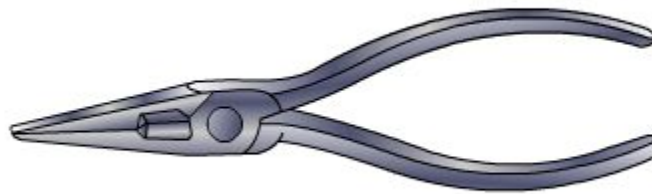

**Diagonal-cutting pliers** are used to cut electrical wire and tape as well as a variety of other material. Diagonal-cutting pliers are well-suited for removing cotter pins on front-end components.

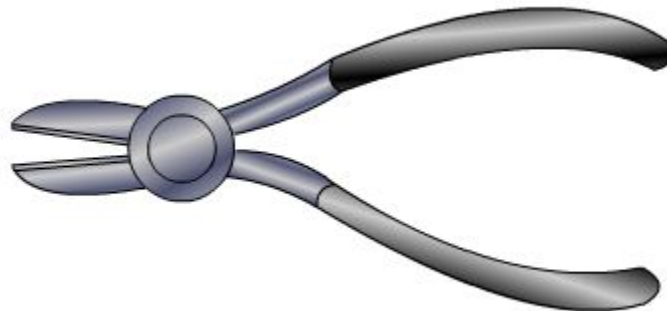

**CAUTION:** Do not use on live electrical circuits.

**CAUTION:** Do not cut spring steel with diagonal-cutting pliers because the pliers will be nicked and ruined.

**Snap-ring pliers** come in many styles and types. Snap-ring pliers are required for spreading or compressing springy snap rings found in transmissions. Snap-ring pliers are available that can remove internal snap rings, external snap rings, or both.



### Maintenance

- Pliers should be kept free of dirt and grease and stored in a dry place to prevent rust.
- If the jaws of the pliers are held by a screw, the screw should be kept snug.

### Safety

- When working near electrical equipment, use pliers with insulated handles.
- Do not use pliers as a hammer.
- Do not hammer on the handles.

## TYPES OF HAMMERS, PUNCHES, AND CHISELS

### Hammers

**CAUTION:** Wear protective eyewear at all times when using a hammer, punch, or chisel to protect the eyes from flying metal chips. Never strike one hammer with another, because hammer heads are very brittle and metal chips can fly off.

The **ball peen hammer** is the most common hammer used for driving punches and chisels. It has a domed head on one side and a flat head on the other.



A **hand-held sledgehammer** can be used when a great deal of driving power is required.



A **soft-faced hammer** can be used to avoid damage to the work being driven. The head can be made of brass, bronze, rubber, or rawhide as these materials do minimal damage to iron and steel components.

A **plastic-tip hammer** is used when light driving power is needed and a brass hammer could cause damage.



**CAUTION:** Do not use this hammer to drive punches and chisels. It will destroy the plastic tip.

A **rubber mallet** is useful for installing wheel covers. Always strike the wheel cover evenly around the perimeter.



### **Maintenance**

- Hammers should be kept free of dirt and grease, with the faces smooth and free of all foreign matter.
- Hammers should be stored in a dry place to prevent rust.

### **Safety**

- Always be sure the head is secured firmly on the handle.
- Be sure the handle is in good condition.
- Strike a flat-surfaced hammer flat against the object being struck, not at an angle.

## Punches

A **taper punch** or **starting punch** is the most commonly used punch. This punch is designed to drive out rivets after the heads have been removed. It is also used to punch out straight and tapered pins.



A **pin punch** is used when a small roll pin must be driven through a hole.



The **center punch** is used to make a small dimple in metal prior to drilling. This mark helps ensure that the hole will be drilled in the proper place and that the drill bit will not move.



A brass punch or bronze punch is used when in an area where flammable liquid or gasoline is present. This ensures that no sparks will be created.



## Chisels

The **standard cold chisel** is used to cut and remove metal. The end of the chisel should be ground to a sharp point on a 60° angle.



Different chisel shapes are available for particular jobs. The shapes include the round nose, diamond point, and half round. These chisels are used to cut or chip metal.

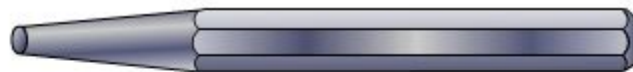

Round Nose



Diamond Point

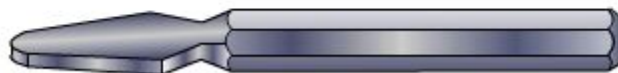

Half Round

### **Maintenance for punches and chisels**

- When the head of the punch or chisel mushrooms, the mushrooming must be ground off with a grinding wheel.
- When the cutting edge of the punch or chisel becomes dull and chipped, it must be sharpened with a grinding wheel.
- After a certain amount of maintenance with the grinding wheel, the punch or chisel becomes too short or the edge becomes too blunt. When this happens, it should be discarded.
- Punches and chisels should be kept free of dirt and grease and should be stored in a dry place to prevent rust.

### **Safety for punches and chisels**

- Always wear heavy gloves and safety glasses when working with punches and chisels.
- Grind down a mushroomed head immediately. The mushroomed metal may fly off and cause injury. Also, the hammer slips off of a mushroomed head more easily.
- Punches should be tapped gently rather than with brute force. Usually several light hits on the head work better for all purposes than a heavy hit.
- Use a chisel holder to minimize the risk of missing the chisel and hitting a hand.



## SPECIALTY TOOLS

### Special Cutting Tools

**Hacksaws** cut metal parts to size or shape and remove damaged fasteners. The hacksaw cuts on the forward stroke only and is lifted on the return stroke. Hacksaws are sized according to blade length. When installing the blade, point the teeth away from the handle and tightly secure the blade.

**CAUTION:** Always wear safety glasses and heavy gloves when using a hacksaw. The blade can break. In addition, be sure to firmly secure the object being sawed.

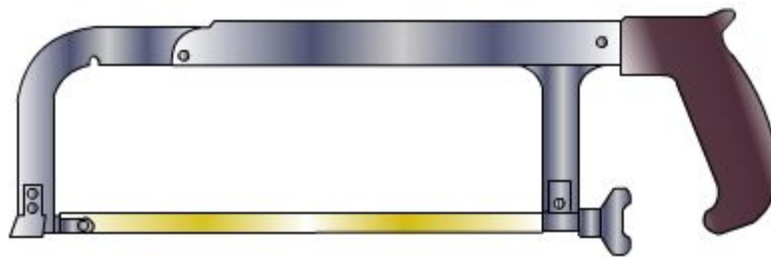

**Tubing cutters** cut without bending, kinking, or scarring the tubing. The cutter is placed on a piece of tubing and tightened as it is rotated. Tubing cutters vary in size according to the diameter of the tube they are designed to cut.

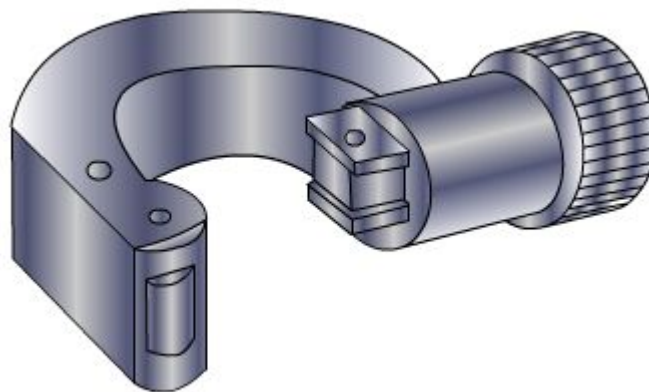

A **hand reamer** smooths or enlarges holes. Both straight and tapered reamers are used. Straight reamers may be either fixed in size or adjustable through a specific cutting range.



**Files** smooth or shape metal. Files are designed in various shapes for different tasks and have different teeth designs for fine or rough work.

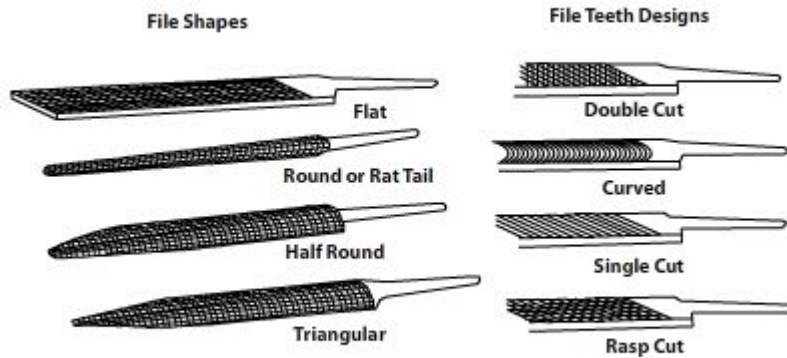

**CAUTION:** Use a handle on the file to prevent hand injury. Never hammer on or use a file as a pry bar. Files are brittle and can shatter with dangerous results.

**CAUTION:** Always wear safety goggles and heavy gloves when working with a file.

## Electrical System Tools

The **digital multimeter (DMM)** checks the condition of electrical system components. This test device is a voltmeter, ohmmeter, and ammeter all in one. A DMM has two leads, one black and one red. One end of the lead is plugged into the DMM. The other end is a probe.

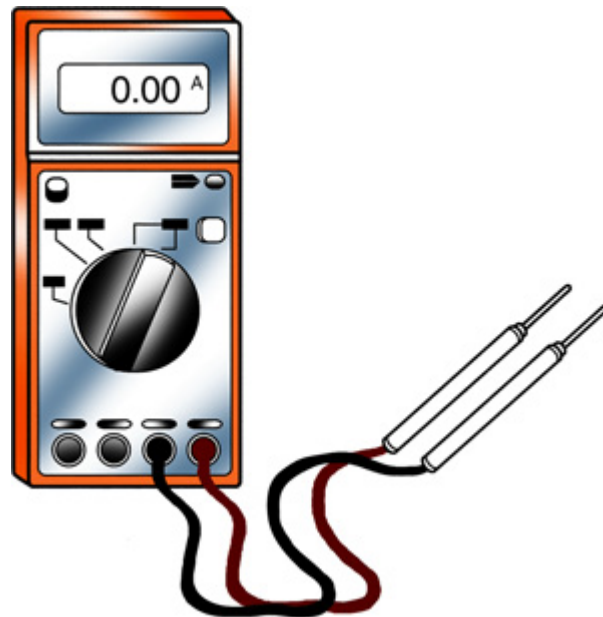

A **scan tool** is used to diagnose electrical problems. The tool is connected to the vehicle's **data link connector (DLC)** to retrieve **diagnostic trouble codes (DTCs)** and engine sensor information that are generated by the vehicle's on-board diagnostics system.



An **oscilloscope**, or scope, is a voltmeter that displays voltage in relation to time, showing voltage vertically and time horizontally. Its connections are similar to a DMM. It produces a line on a cathode ray tube (CRT) or liquid crystal display (LCD) when connected to circuit voltage. A circuit problem can be found by comparing the line "pattern" to a known good pattern.

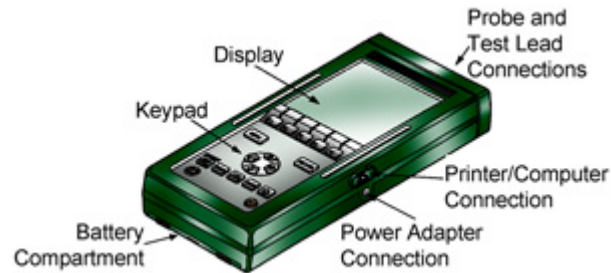

The **continuity light** checks power in various circuits. One end of the light is grounded and the other end is pressed into the electrical device.

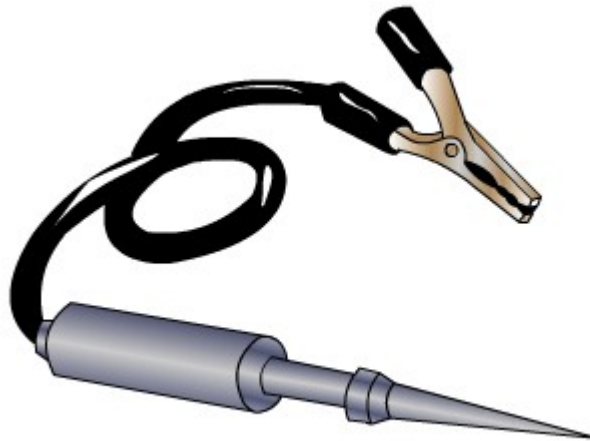

**Note:** The continuity light should never be used to check the power supply of electronic components.

A **timing light** determines if the ignition system is delivering electric charge to the spark plugs at the correct time.



The **remote starter switch** allows the technician to use the starter to crank the engine without actually being in the vehicle.



A **cable puller** removes the cable from the battery terminal without breaking the cable or battery posts.

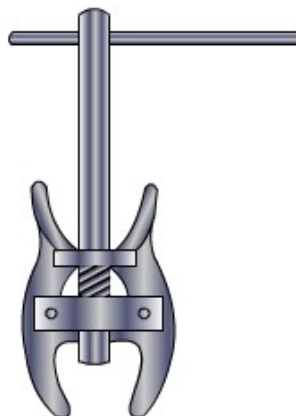

**Terminal and post cleaners** clean the posts and terminal ends.

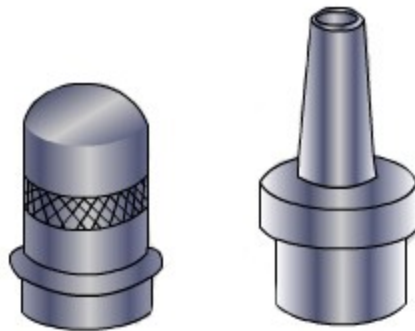

A **battery lifting tool** and **carrying strap** lifts and transports the battery safely.

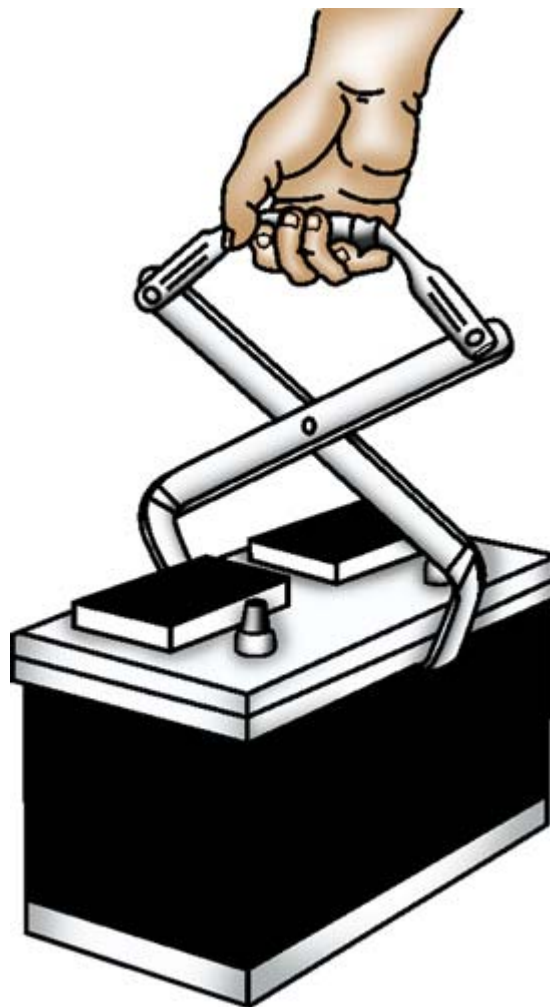

## Lubrication Specialty Tools

A **transmission funnel** is a funnel with a long, small, flexible neck that is ideal for adding transmission fluid.

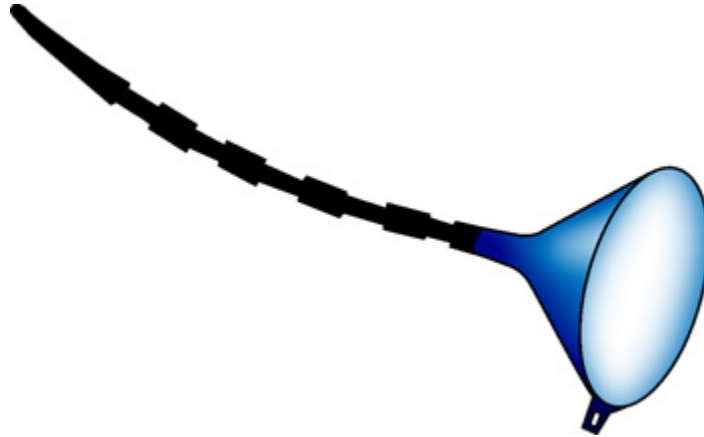

An **oil filter removing tool** is a wrench or socket adapter that fits around an oil filter to remove it.



A **grease gun** forces grease into fittings. Pressure is created by hand action on the gun's lever.



## Miscellaneous Specialty Tools

A blowgun uses compressed air to clean or dry various items in the shop.

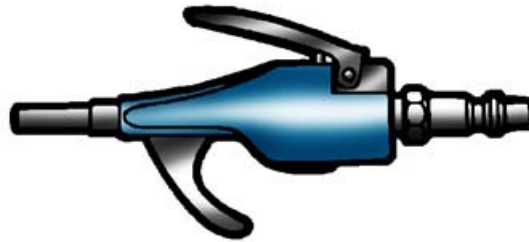

The **C-clamp** is a holding device that is commonly used to compress the calipers on floating caliper disc brake systems.



A **puller set** functions to remove objects (e.g., gears, bearings) that are pressed onto a shaft, pull objects (e.g., retainers, oil seals) from various openings, and remove shafts (e.g., pinion shafts, transmission shafts ) from another object.

**Pressure gauges** test the air and fluid pressure in various components such as the tires, oil pump, and fuel pump.

**Vacuum gauges** check the condition of the engine and various vacuum-operated components. Gauges compare the pressure in a component to atmospheric pressure at sea level.





## FASTENERS

### Common Vehicle Fasteners

**Note:** Vehicles use many types of fasteners to hold various components together and technicians need to be familiar with each type. Some of the more common types of threaded fasteners include nuts and bolts, washers, screws, and studs. Other common fasteners include snap rings, rivets, and adhesives.

**Note:** American automobile manufacturers have largely switched to the metric system of sizing fasteners and threads.

### Nuts and bolts in the U.S. Customary System (USCS)

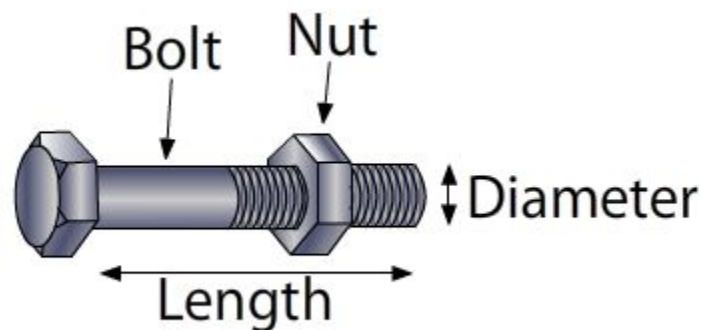

Bolt diameters come in increments of 1/16 in, starting with 1/4 in. The measurement is the overall diameter of the bolt threads.

**Note:** It is easiest to measure the unthreaded or shank portion of the bolt.

The length of a bolt is its effective length measured from under the head to the end of the threads. Bolt lengths usually come in 1/4-in increments, starting from 1/2 in. The longest bolts normally used in the field are 6 in. Thread type is either fine or coarse. Do not thread fine-threaded bolts into coarse threads or vice versa.

**Note:** Nuts are very difficult to measure for diameter, so it is usually best to trial fit the nut onto a bolt and then measure the bolt.

Thread size is determined by measuring the number of threads per inch. A **thread gauge**, available in both metric and USCS, can be used to determine the thread size of bolts.

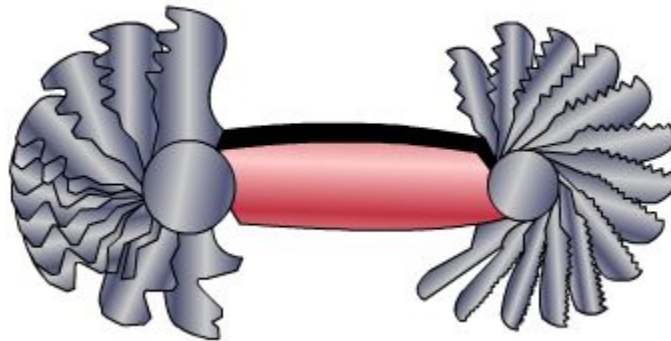

The strength of a bolt is important. A bolt that is not strong enough can break. The strength or hardness of a bolt is determined by counting the points or slashes on the head of the bolt.

**CAUTION:** Never substitute a bolt with one of less strength. A lower strength bolt may break and cause injury and system failure.

Grade 1 or 2 bolts have no points and are unsuitable for automobile assembly due to their unknown and possibly low strength. Grade 5, or 3-point, bolts have three points on the head. These bolts are the most common in automobile assembly. Grade 8, or 6-point, bolts have six points on the head. These bolts are expensive but very strong and are used in high-stress conditions. Examples of grade 8 bolts include harmonic balancer bolts, flywheel bolts, and steering linkage bolts. Never substitute a lower grade bolt for a grade 8.

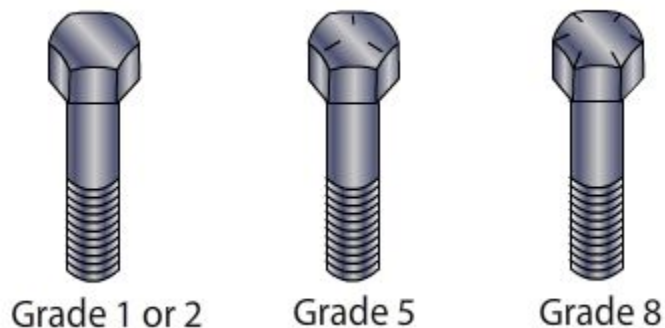

Right-hand thread nuts and bolts are the most common and turn clockwise to tighten. Left-hand thread nuts and bolts also are available that turn the opposite way. Left-hand nuts and bolts have notches cut at the corners of the hex head or the letter "L" stamped on them.

**Note:** Very old automobiles (built before 1960), Chrysler products up until the early 1970s, and Ford vans up through the mid 1980s have left-hand thread wheel lugs only on the driver's side.

## Nuts and bolts in the metric system

The diameter of a metric bolt or nut is measured in the same way as in the USCS; however, the diameter of a metric bolt is expressed in millimeters. The bolt is measured for its effective length from under the head to the end of the threads. Thread size in the metric system is determined by measuring the distance from the crest of one thread in millimeters to the crest of the next thread. Metric bolt strength is indicated by a number stamped on the bolt head. This number is called the property class. Examples of property class numbers include 4.6, 4.8, 5.8, 8.8, 9.8, and 10.9. The higher the number, the stronger the bolt.

**CAUTION:** Never substitute a bolt with one of less strength. A lower strength bolt may break and cause injury and system failure.

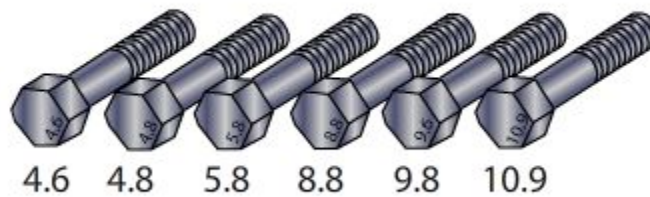

## Washers

**Washers** are frequently used with threaded fasteners. They fit onto a bolt or screw between the surface being fastened and the nut, or under the bolt or screw head. Washers have two main functions. They improve the fastening ability by increasing the area that is clamped, and they prevent the bolt or nut from damaging the part surface.

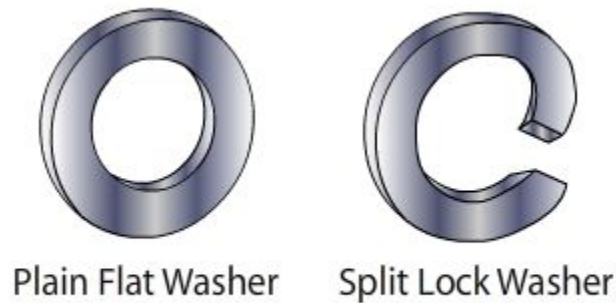

## Types of screws

Many sizes and types of screws are used to fasten automotive parts. Two of the more common types are the following:

**Machine screws** are used in threaded holes to clamp small parts together.

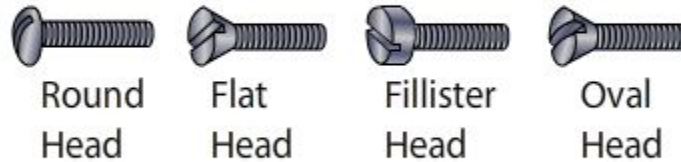

**Self-tapping screws** (also called sheet metal screws) have hard, tapering threads that make their own threads when driven into a surface.



## Studs

**Studs** have threads on each end and no head. Some studs have threads throughout their length. Fastening with studs is accomplished by threading one end of the stud into a part, placing another part over the stud, and fastening the other end of the stud with a nut. Studs are useful for achieving accurate alignment of parts.



## Snap rings

Snap rings (also called **retaining rings**) are used to hold components such as shafts, bearings, and gears in place. Internal snap rings fit in a groove inside an opening and external snap rings fit in a groove on the outside of a part. Snap-ring pliers are required for installing and removing snap rings.

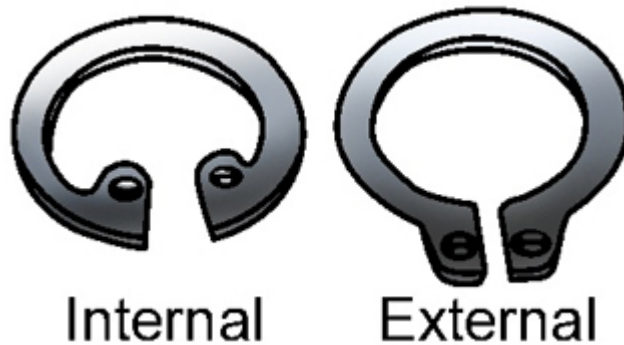

## Rivets

A rivet is a nonthreaded metal pin with a head on one end. Rivets are available in different designs and are typically made of copper, steel, or aluminum. Rivets are used to fasten parts that are not usually taken apart. Parts are joined together with a rivet by putting the rivet through a hole in the parts and hammering the headless end with a ball peen hammer or hammer and rivet set until the end is rounded. Rivets are removed by cutting off the head with a chisel and driving out the pin with a punch.

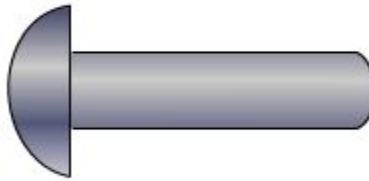

## Adhesives

Various types of **adhesives**, or glues, are used to bond parts together. Parts that may be glued include trim, moldings, and various plastic and rubber parts.

**CAUTION:** When using adhesives, it is important to follow the manufacturer's specifications because some adhesives are toxic, flammable, and harmful if inhaled.

## Cutting Threads, Repairing Threads, and Removing Broken Bolts

### Types of taps

The **taper tap** is the most commonly used tap because the taper allows easy starting. It cannot cut threads to the bottom of a blind hole, a hole that does not go completely through the metal. The **plug tap** cuts threads part of the way to the bottom of a blind hole. A **bottoming tap** cuts threads all the way to the bottom of a blind hole but cannot start the cutting process. A **taper tap** must be used before the bottoming tap. The **machine screw tap** cuts the small-diameter threads of numbered screw sizes.

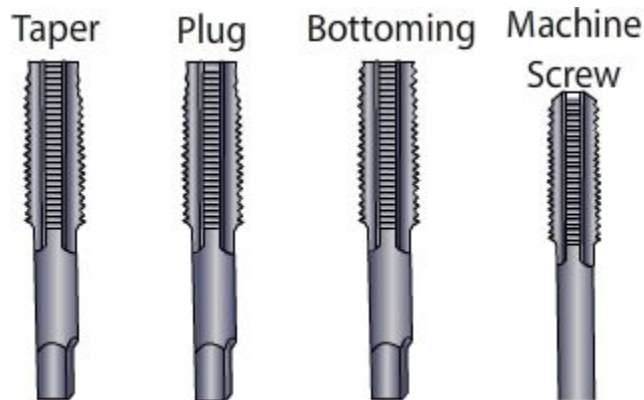

The sequence for cutting threads with a tap is shown below.

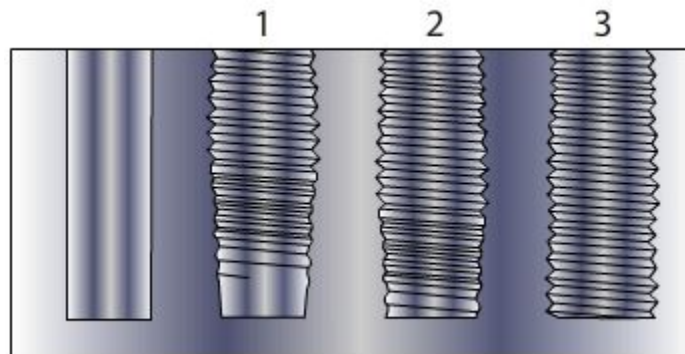

### General procedure for using a tap

**CAUTION:** Before drilling a hole to cut threads, choose the correct drill bit size for the thread size. Failure to use the correct drill bit size can result in a broken tap or inadequate thread depth.

First apply a thread cutting oil.

Start the handle with the tap straight and then make a half turn.

After each partial turn, back the tap off until the metal chips begin to break loose.

Repeat this process until all of the needed threads are cut. Add oil as needed during the process.

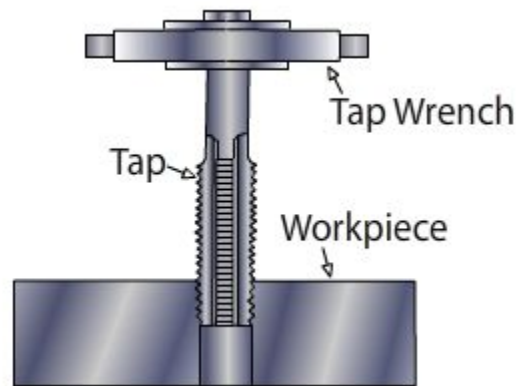

### Using a die to cut threads onto a rod

A special die stock holds the die for the cutting process.

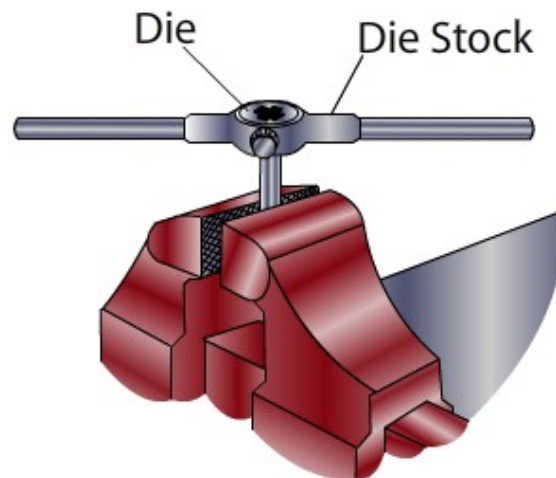

Dies are selected in the same manner as taps, but the die can be improperly placed in the die stock. The die should be positioned in the die stock so that the tapered end engages the rod first.

### General procedure for using a die

First apply a thread cutting oil.

Put the tapered side of the die on the rod.

Start the die stock with the die straight and then make a half turn.

After each partial turn, back the die off until the metal chips begin to break loose.

Repeat this process until all of the needed threads are cut. Add oil as needed during the process.



## Procedures for repairing damaged or stripped threads

**Chasing threads** involves using a standard tap or die to run through existing threads of the same size. The purpose of this procedure is to correct small imperfections that interfere with the threading of the nut or bolt.

**Note:** Use a thread cutting oil during this procedure.

When threads in a hole are so severely damaged that they cannot be adequately repaired by chasing, a **helicoil** can be installed to restore the threads back to their original sizes. The basic steps for this procedure are as follows:

- Completely drill out the old, damaged threads with a drill bit supplied in the helicoil kit.
- Tap with a special tap from the kit.
- With a special handle, screw in an insert that looks like a spring or coil. The inside of this coil is the same as the original thread of the hole.

A **thread insert** can also be used to repair damaged threads. The insert is almost identical to the helicoil but is somewhat larger. It is retained in place by driving down four pins around the insert.

**Thread repair cement** can be used on low-torque applications. The cement is applied to the bolt, and the bolt is then placed back into the damaged hole. New threads are molded as the glue-like substance hardens.

## Procedures for removing a bolt that is broken off in a threaded hole because of overtightening

A **screw extractor** can be used to remove bolts. The screw extractor has flutes or grooves that spiral in a counterclockwise direction.

- Drill a hole in the center of the broken bolt.
- Insert a screw extractor in the hole.
- Use the tap handle to rotate the extractor and bolt counterclockwise and remove them as a unit from the bolt hole.

Use the following procedure to remove a bolt that is not bound to the threaded hole.

- Drive a sharp punch into the center of the bolt.
- Use pliers to retrieve the bolt.

**Note:** Breakage due to the wrong thread design, a cross-threaded bolt, or a bolt that is bottomed out in the hole can make removal difficult. Drill out the bolt and retap the hole. Use the correct bolt and start it into the hole with the fingers.

## MEASURING TOOLS

### Types and Uses of Common Measuring Tools

**Note:** Some vehicle components, particularly in the engine and transmission, contain precision-machined parts that require precise measurements for inspection or replacement.

The **outside micrometer** is used when an outside measurement must be accurate to .001 in or less. Parts requiring these measurements include crankshafts, pistons, valves, and camshafts.



The **inside micrometer** is used when a measurement of the diameter of a hole must be accurate to less than .001 in. Examples of such holes are cylinder bores and main bearing bores.

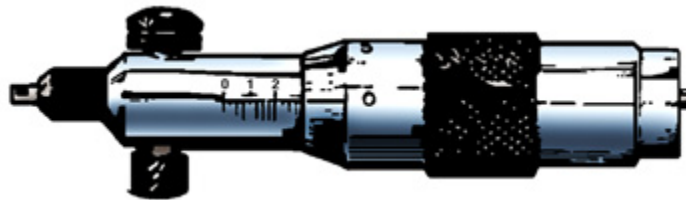

The **depth micrometer** makes precise depth measurements of holes or cavities. For example, it can be used to measure the distance from the center of the crankshaft to the top of the engine block (deck height) and the distance from the top of the piston to the top of the engine block (piston deck clearance).

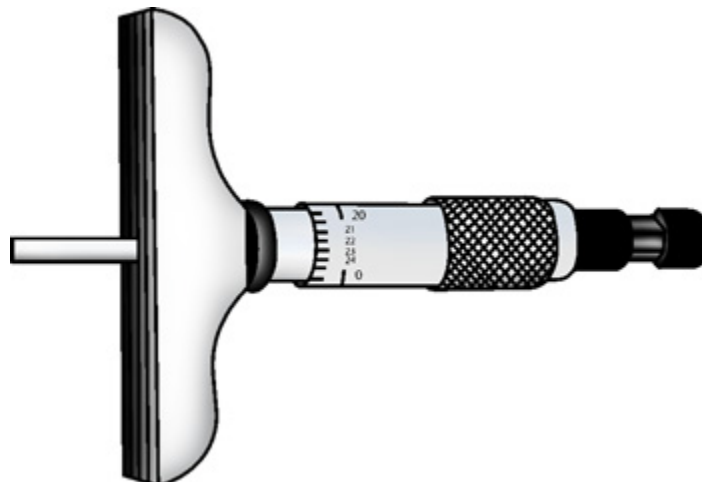

The **dial indicator tool** measures thrust, back-and-forth movement, and runout (side-to-side play). These measurements are made on valves, crankshafts, and flywheels. The dial indicator can also measure the backlash or movement between gear teeth.



A **feeler gauge** measures air gaps and clearance between moving parts and has numerous flat leaves of different specific thicknesses.

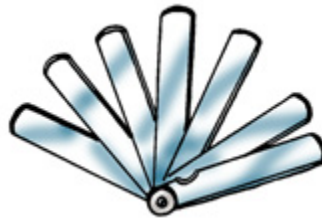

A **dial caliper** is used for inside, outside, and depth measurements. One application is measuring bolts and small machined parts.

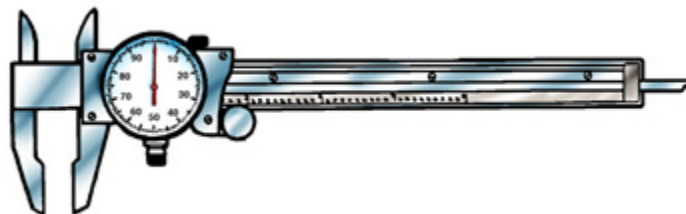

**Plastigage** is a tiny strip of clay-like material that measures clearances such as between engine bearings and their journals and main bearings and connecting rod bearings. The strips are color coded according to the clearance range.

## Procedures for the Use and Care of Measuring Tools

**CAUTION:** The proper care and use of precision measuring tools are critical to the accuracy and long life of the tool. An incorrect measurement can result in expensive component failure.

### Using an outside micrometer

Before using an outside micrometer, become familiar with its parts. See the illustration below.

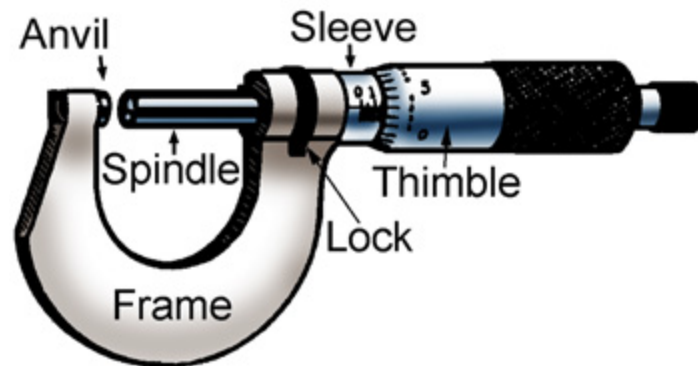

**Note:** The outside micrometer does not readily display the measurement. Some addition is required in order to arrive at the micrometer reading. The technician must develop a feel for the outside micrometer in order to achieve accurate results.

- Place the object to be measured between the anvil and spindle and turn the thimble until the object is lightly contacted by the anvil and spindle. Lock the spindle and remove the micrometer from the object.
- Read the number indicated on the micrometer sleeve (upper scale). Each number represents one tenth (.100) of an inch.
- Add 25 thousandths (.025) of an inch for each additional line showing on the sleeve (lower scale) past the number.
- Add the number of thousandths (.001) of an inch indicated on the thimble.
- Add the number of inches of the minimum dimension that the micrometer can read 0 in through 5 in.

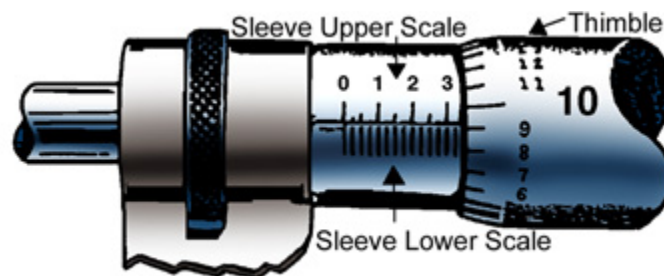

Reading an inside micrometer and depth micrometer is similar to reading an outside micrometer. Be sure to add the correct figure for the minimum measurement.

## Using a dial indicator

- Securely attach the dial indicator so it will not move and give inaccurate readings. The dial indicator is positioned with a clamp-on base or with a magnetic base.
- Position the plunger against the part being measured.

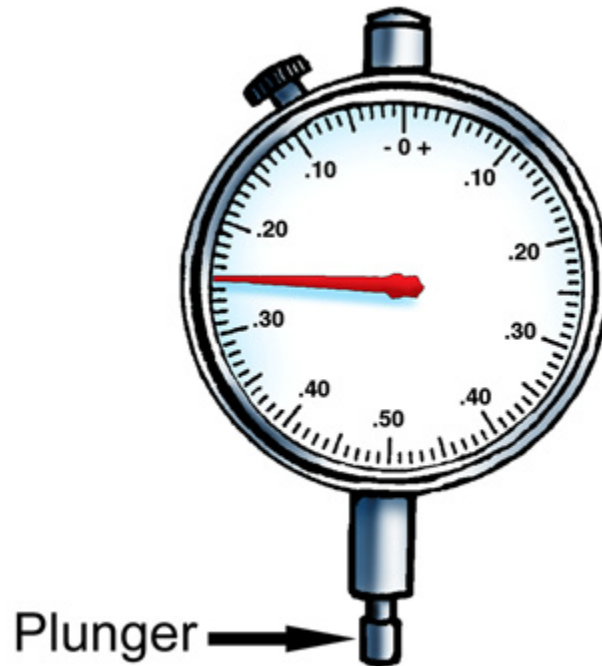

- Rotate the indicator until the needle is on zero. If making a thrust measurement, the shaft or gear that is to be measured must first be pried one way.
- Rotate the part for runout measurements or pry the gear or shaft for thrust measurements, and note the reading in thousandths of an inch on the dial.

## Using a feeler gauge

- Select a sample leaf and make a trial fit between the two surfaces.

**Note:** The thickness of the leaf is printed on the leaf.

- If the leaf is too loose or too tight, try another leaf.
- When there is a slight, smooth drag as the feeler gauge is removed, the correct leaf has been found. The size printed on the feeler gauge is the clearance.
- After use, put a little oil on the leaves to prevent rust.

## Using a dial caliper

**Note:** A dial caliper is accurate to approximately + or - 0.002 in. When more precision is required, use a micrometer.

Before using a dial caliper, become familiar with its parts. See the illustration below.

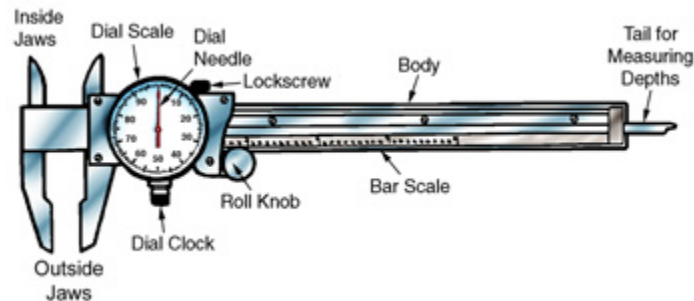

- Adjust the dial caliper with the roll knob until the jaws lightly contact the work.
- Read the measurement on the linear scale and add the reading on the dial.

## Using Plastigage

- Select a small piece of Plastigage material.
- Place the Plastigage material on the crankshaft journal. The Plastigage piece must span the full width of the journal and be centered with the bearing cap.
- Install the bearing cap and tighten to the proper torque.
- Remove the bearing cap and inspect the Plastigage. It should appear somewhat smashed. Compare the width to the paper gauge on the Plastigage package.

## Care of measuring tools

- Adjust precision measuring tools carefully. For example, only very slight pressure is needed to tighten the thimble on a micrometer. Overtightening can destroy the adjustment.
- Do not attempt to adjust measuring tools with the lock on.
- Always store measuring tools in their case or in a safe place to protect them from damage, grease, dirt, and moisture.
- Check the calibration of precision measuring tools frequently. Consult the manufacturer's instructions for the proper procedure.

# POWER TOOLS

## Principles of Using Power Tools

### Electric tools

**Note:** Electric hand tools are still in use in shops, but some have been replaced by pneumatic (air-operated) equipment, which is usually lighter.

**Electric tools** are driven by an electric motor. Using electrical equipment is a matter of common sense and using good safety practices.

### Safety

- As with any electrical devices, be aware of the dangers of electric shock.
- Do not stand on wet ground or a wet surface when operating an electric tool.
- Always check that the power cord will not be damaged by the operation of the equipment and do not run over power cords with any heavy object.
- Always check that the power cord is not frayed or worn.
- All electric tools must have a three-pronged plug unless the tool is double insulated. Double-insulated tools cannot short to the outside case and require only a two-prong plug.

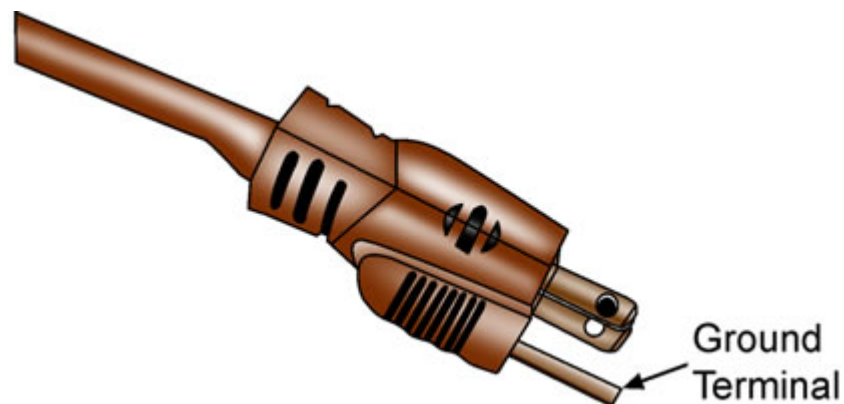

- Do not eliminate the ground terminal of a three-prong plug by using an adapter or clipping the terminal.
- Do not put cords in water or across moving machinery.
- Wrap up cords carefully after use and store them properly.
- Keep hands and clothing away from the moving parts of electrical equipment.
- When inspecting or making adjustments to electric tools, always disconnect them from the power supply.

### Maintenance

- Check the service manual for the equipment being used.
- Electrical equipment should be kept free of dirt and grease and should be stored in an area that is dry and free of dust.

## Pneumatic tools

**Pneumatic tools** are powered by compressed air. Pneumatic tools have advantages over electric tools. They are lighter and, unlike electric tools, are not damaged by overloading or stalling. Although there are dangers associated with compressed air, the dangers are not as great as those associated with electricity.

### Safety

- Operate air tools only for their intended purpose.
- Air impact guns, air hammers, and air drills can create flying metal chips that are dangerous to the eyes. Wear protective eyewear at all times when working with or around air tools.

**CAUTION:** Wear personal protective equipment (PPE) when flying metal chips are possible.

- Pneumatic tools produce a great deal of power. Using an improper attachment or placing the attachment on the tool incorrectly can result in breakage. Use only impact sockets on air impact guns.
- Water and oil can accumulate in air compressors. These should be drained daily. It is possible for compressed air to carry infection even with daily draining.

**CAUTION:** Do not play with compressed air blowguns or hoses. The high-pressure air stream on the skin can cause severe infection, require the amputation of a limb, and cause death.

- Pneumatic tools create a great deal of noise. Wear ear plugs, ear muffs, or other types of ear protection.
- Do not look into the air-outlet valve or nozzle on any piece of air-powered equipment.
- Do not grab the movable portion of an air-powered tool with the hand when it is hooked up to the air line.
- When inspecting or making adjustments to pneumatic tools, always disconnect them from the air supply.

### Maintenance

- Before any new air tool is used, three or four squirts of air tool oil should be applied to the air inlet to flush any dirt or moisture from the rotor and to lubricate the moving parts. Do not use air tool oil around an open flame as it is highly flammable.
- Oil pneumatic tools regularly according to manufacturer recommendations.
- Pneumatic equipment should be kept free of dirt and grease and should be stored in an area that is dry and free of dust.
- Care should be taken that no foreign matter enters the nipple opening of the couplings on pneumatic equipment.



## Basic designs of pneumatic tools

**Rotary** — The air drives a rotor (turbine) that spins a shaft and provides the power.

**Reciprocating** — The air drives a piston that is forced back and forth by the compressed air.

**Note:** The exceptions to the above two kinds are blowguns and paint-spraying equipment, which use a direct stream of air.

## Pneumatic couplings

Pneumatic equipment is connected to air supply equipment through quick couplers. The quick coupler is on the end of the air supply hose and connects into a nipple on the equipment. On some tools, the manufacturer recommends attaching a short leader hose to the tool and installing the nipple at the end of the leader hose. The quick coupler operates by pulling back a collar on the coupler, which allows the nipple to be inserted into the coupler. When the collar is released, it locks the nipple into the coupler.

## Cordless tools

These tools use a battery cell as the power supply, instead of electricity from a wall outlet. They are convenient in shops due to portability and the absence of power cords; however, frequent recharging is necessary.

## Safety

- Always disconnect a cordless tool from its battery before inspecting it and making adjustments to it.
- Use only the battery specified by the manufacturer for the tool being used.
- Always store battery packs safely so that no metal can come in contact with the terminals. Contacting the terminal can short-circuit the battery and cause sparks, fire, or burns.

## Hydraulic tools

**Note:** Most hydraulic tools fit in the category of shop equipment, which is discussed in the next lesson.

**Hydraulic tools** use pressurized fluid within a cylinder to create great pressure. The fluid is **hydraulic fluid**, a petroleum product that is much like oil. The hydraulic pressure within the tool is created by air pressure or the manual pumping of a handle. Common hydraulic tools and equipment used in the shop include jacks, lifts, hoists, and presses.

## Safety

- Before operating a hydraulic tool, inspect its parts to make sure none are damaged or deteriorated.
- Keep hydraulic hoses away from potential damage such as grease, oil, sharp objects, and hot surfaces.
- Before using a hydraulic tool, consult the manufacturer's information to be sure it is appropriate for the task and that the task will not exceed the tool's load limit.
- Check hydraulic tools frequently for leaks. Leaks can cause the tool to fail, with dangerous results.

## Maintenance

- Check the service manual for the tool being used.
- Inspect tool components and report any damage, leaks, or deterioration to the instructor.

## Power Drills

**Electric drills** can be used interchangeably with pneumatic drills. Drills are used with drill bits to drill holes or with special attachments to remove rust or gasket material.

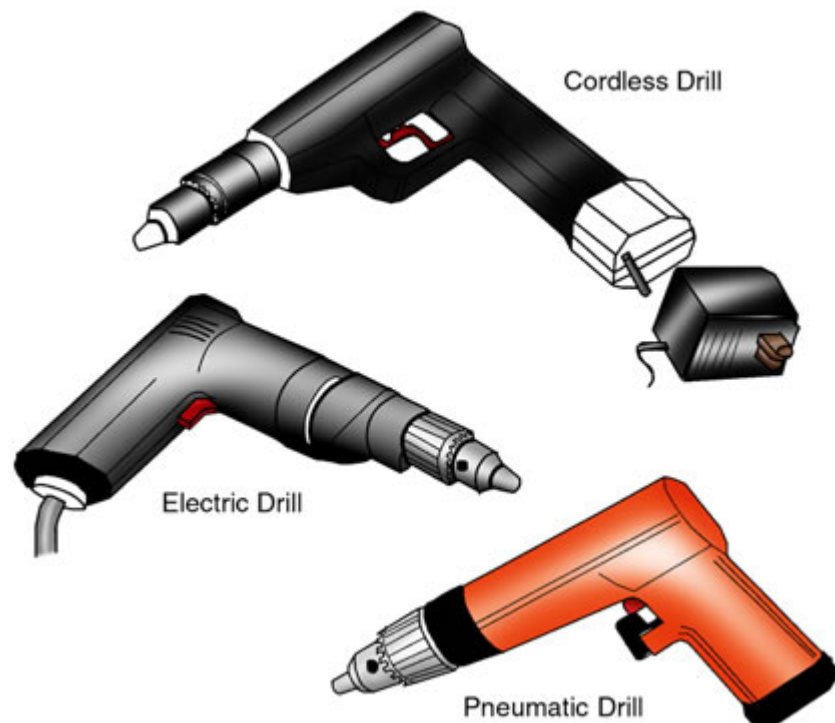

Electric drills use an electric motor to drive a **chuck**, a device that holds the drill bit in place and aligns it properly. Pneumatic tools use a rotor, which drives the chuck. A **chuck key** is used to loosen and tighten the chuck. Drills are also available with keyless chucks.

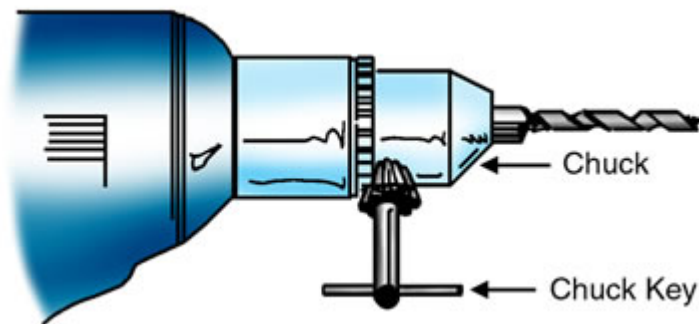

The size of the drill is determined by the maximum diameter of the drill bit shaft that the chuck holds. For example, a 1/4-in drill holds a drill bit with a shaft diameter no larger than 1/4 in. The most popular sizes are 1/4 in, 3/8 in, and 1/2 in.

### Drill bits

**Drill bits** come in various sizes and lengths and are interchangeable between electric and pneumatic drills. When looking for a particular size of drill bit, use a drill gauge. Drill bits are made of high-grade steel and, if used properly, they seldom need sharpening. Drill bits are sized according to the size of hole they drill. Do not use metric drills in place of United States Customary System (USCS) drills or vice versa. If a 12-mm hole is required, use a 12-mm bit.

### Safety for power drills

- Make sure the bit is tightly seated in the chuck, securing it by turning the chuck key in each hole. Be sure to remove the chuck key before starting the drill.
- Make sure the work is firmly secured before starting to drill.
- Keep a firm grip on the drill and be ready to shut it off if it jams. Drills often jam just as they are about to penetrate what they are cutting.
- If an electric drill jams, turn the drill off and pull it back out, then start it and continue to drill the hole. The same procedure should be performed for restarting a pneumatic drill. Such jamming may damage an electric drill.
- Remove the bit from the drill when the work is completed.

## Power Wrenches

### Impact wrench

**Impact wrenches** can be either pneumatic or electric and are used to drive impact sockets to loosen or tighten nuts and bolts. They use sockets that are specially made to have greater strength than standard sockets.



The **wheel torque socket**, also called a torque stick, is a type of socket commonly used with impact wrenches. **Torque sticks** are long-shafted sockets that work in combination with an impact wrench to install lug nuts on wheels. They are designed to flex when the proper torque is reached, helping to prevent the damage that can result from overtightening. The sticks are color coded per socket diameter and torque limit.

**CAUTION:** Torque sticks are designed for tightening lug nuts, not loosening them; using torque sticks to loosen lug nuts will damage the sticks.

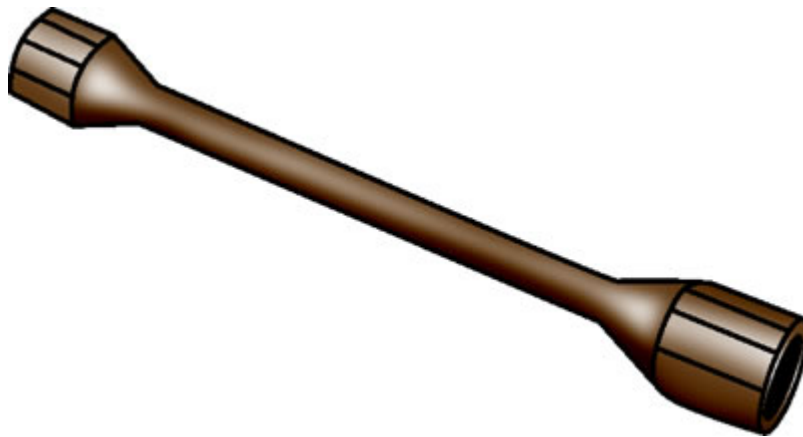

### Using impact wrenches

- A built-in regulator allows for adjustments in speed and torque. However, do not rely on the regulator to adjust the amount of torque accurately. Final tightening should be done with a torque wrench.
- Hold the wrench with a slight forward pressure on the bolt or nut.
- Soak rusty bolts and nuts with penetrating oil before using an impact wrench to loosen them.
- A switch can change the impact wrench from counterclockwise to clockwise operation.

### Air ratchet

The **air ratchet** is a smaller version of the impact wrench and usually uses a 1/4-in or 3/8-in drive lug. It delivers less force than the impact wrench and standard sockets may be used with it. The air ratchet has a switch to change it from clockwise to counterclockwise rotation.

**Note:** An air ratchet should be used only to snug a bolt. A conventional ratchet or torque wrench should be used to complete the tightening of a bolt.



### **Air chisel (air hammer)**

The **air chisel** uses reciprocating motion to provide rapid impact force, much like a rapid series of short hammer blows. Available attachments include cutters, chisels, and punches. The air chisel is often used to break welds loose, cut rivets, punch holes, and shear sheet metal.



### **Safety for power wrenches**

- Always wear PPE when using power wrenches.
- When operating an impact wrench, only use sockets that are made for impact wrenches. If a standard socket is used, it may break or be damaged and fly off of the tool.
- Be sure that the chisel in the air chisel is firmly secured and that the cutting edge is sharp.

## Miscellaneous Power Tools

### Heat gun

**Heat guns** are hand-held heaters that use forced air passing through heated coils. They are used in various repair procedures to soften, loosen, and thaw vehicle components. Specific uses include softening vinyl; loosening sleeves/trim and adhesives; thawing frozen locks, wipers, and weather strips; and heating decals for easy removal.

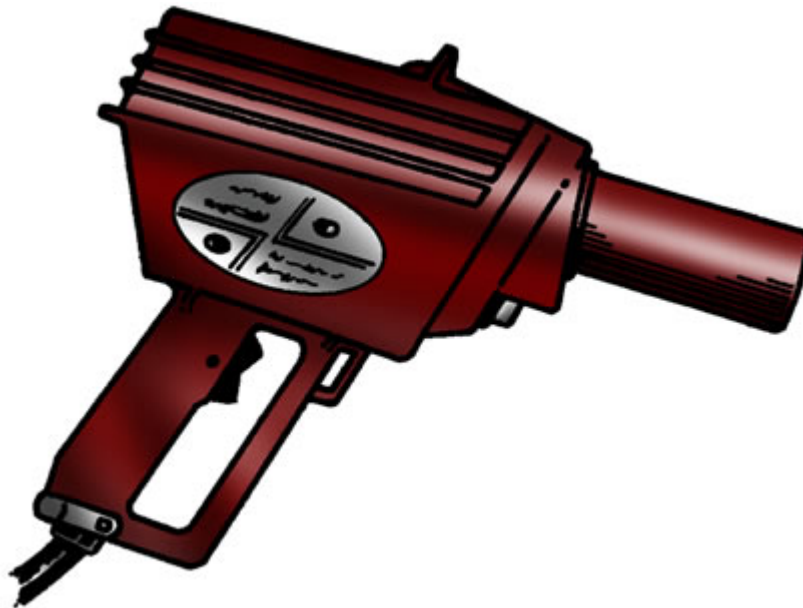

The **tire burnishing tool** is used for tire repair. The wheel makes the rubber on the inside of the tire rough. This prepares the rubber for the application of a tire patch.

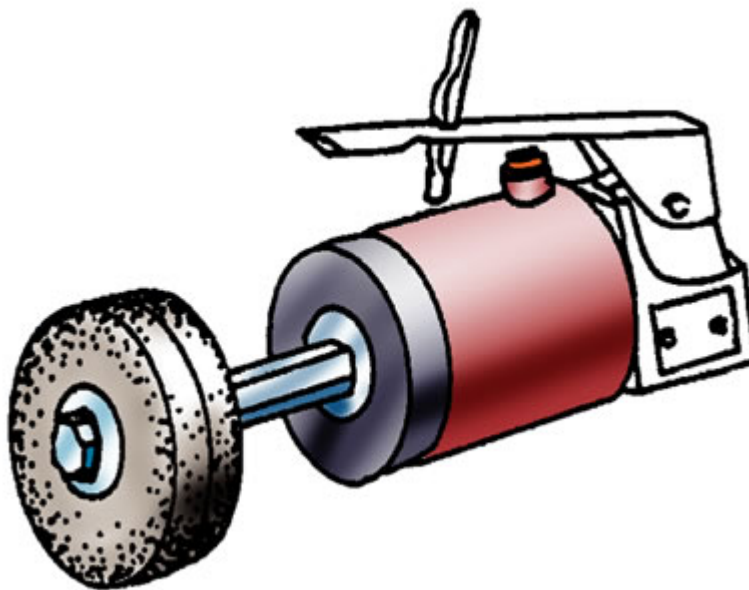

### Mini die grinder

A **mini die grinder** is used for cutting metal; removing gasket material; and cleaning brake rotors, backing plates, and pad mounts. The grinder illustrated has a head angled at 90° for easy access and handling.

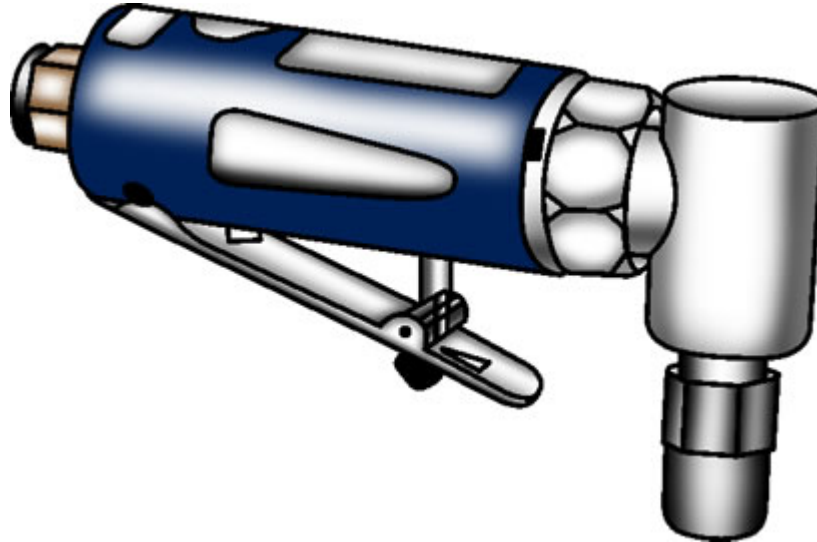

### Blowgun

A **blowgun** is a pneumatic attachment that directs a small, powerful stream of air. A blowgun is used to clean and dry surfaces to be painted and to clean dust from shop equipment.

**CAUTION:** Only blowguns that have an approved pressure limiter should be used in the shop. A proper blowgun attachment limits the maximum pressure to 30 pounds per square inch (psi).

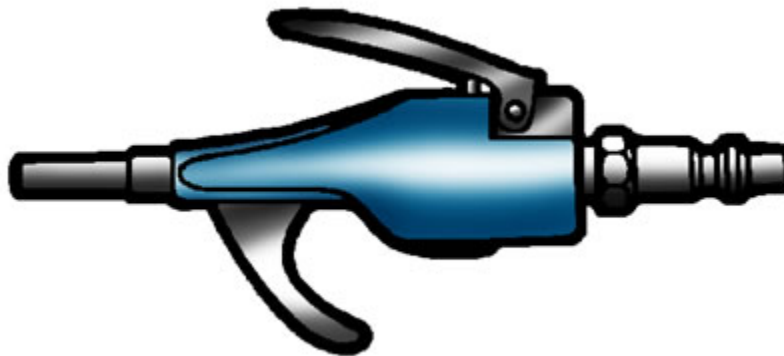



## SHOP EQUIPMENT

### Electrical Equipment

**Note:** The term "shop equipment" refers to large or expensive pieces of equipment or tools, which are generally provided by the shop owner.

#### Wheel balancer

Shops equipped to mount tires have a **wheel balancer**. Many shops now use computerized wheel balancers. Wheel balancers are used to equally distribute weight around the wheel's centerline.

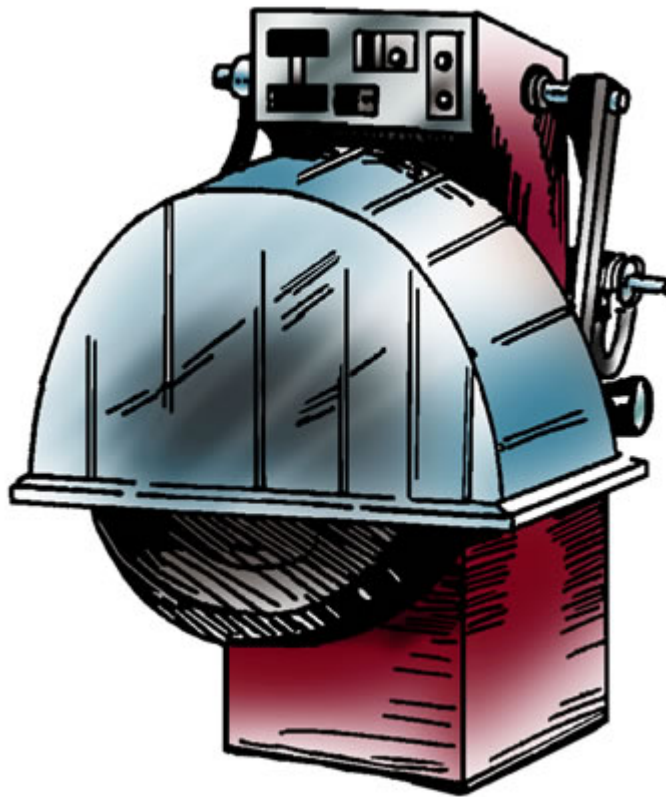

#### Safety

- Consult the instructor before using the wheel balancer.
- As with any electrical devices, be aware of the dangers of electric shock.
- Do not stand on wet ground or a wet surface when operating electrical equipment.
- Ensure the guards are in place before operating the wheel balancer. Be aware of the rotating mass that could cause injury if contact is made.

## Bench grinder

A **bench grinder** is a common piece of shop equipment. A bench grinder is generally used to maintain tools that have become dull and to grind sharp edges from metal pieces. The grinder is mounted to a bench and is powered by an electric motor. In addition to the grinding wheel, the grinder can be used with a wire wheel that cleans rust and dirt off parts.

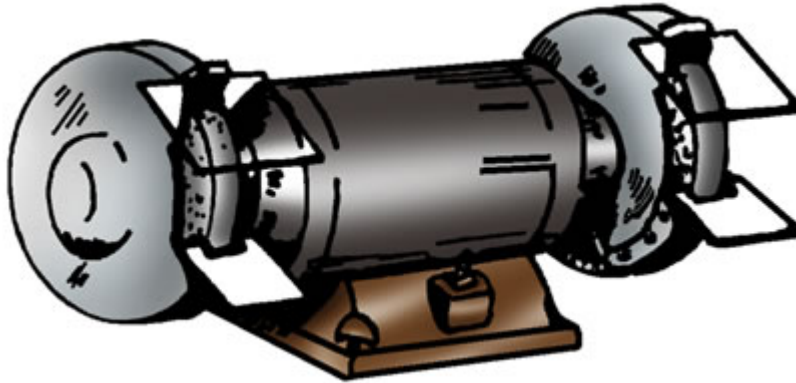

## Safety

- As with any electrical devices, be aware of the dangers of electric shock.
- Always wear safety glasses and a particle mask when working with a bench grinder. Wear a respirator, as needed, for grinding certain materials.
- Be sure that clothing, hair, and other combustibles in the area are protected from the sparks given off by the grinder.
- The bench grinder should have a tool rest platform in front of each abrasive wheel, in addition to a wheel guard and an eye shield.
- Do not put excessive pressure on the wheel because it could break apart. Do not use wheels that are broken or worn.
- Follow the bench grinder manufacturer's recommendations for removing and replacing grinding wheels. Do not overtighten the spindle nut.
- When grinding small parts, never hold the parts by hand. The parts can be very hot and easily propelled through the air by the wheel. Use standard slip-joint pliers to hold small parts.
- Abrasive wheels are designed for specific types of metals. Do not grind aluminum on grinding wheels designed for steel. Aluminum chips will clog the wheel's surface.

## Drill press

Some shops have a drill press for drilling holes in metal parts.

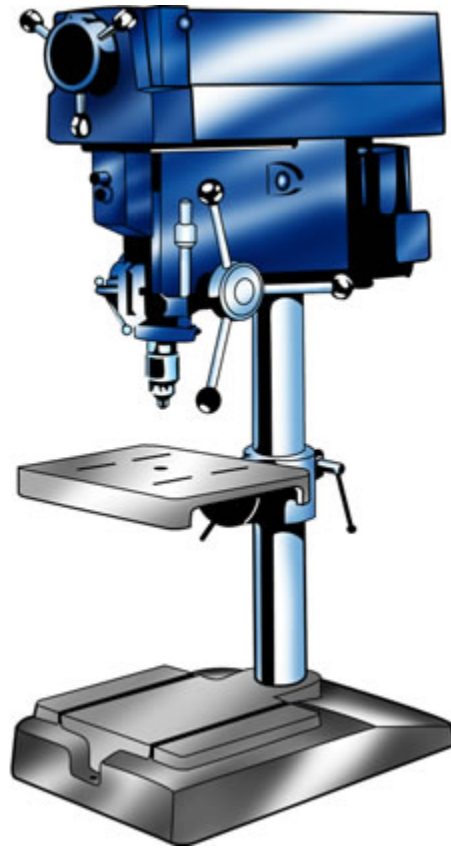

## Maintenance

- Inspect bits regularly. Sharp bits cut better and are less likely to break.
- Oil the bit as needed to prevent binding.

## Safety

- As with any electrical devices, be aware of the dangers of electric shock.
- A full face shield and protective eyewear should be worn.
- Parts drilled by the press must be securely held by a vise or standard slip-joint pliers. This prevents the work from spinning out of control and cutting hands.
- When using the drill press, do not wear loose clothing or jewelry. Do not allow long hair to hang freely.

## Test and service equipment

A variety of electrical test and service equipment can be found in the shop. Each piece of equipment has its unique safety considerations. Consult the instructor before using a new piece of equipment.

## General maintenance guidelines for electrical equipment

- Check the service manual for the equipment being used.
- Electrical equipment should be kept free of dirt and grease and should be stored in an area that is dry and free of dust.

## Pneumatic Equipment

Pneumatic equipment can be permanently attached to the shop air compressor or temporarily attached to the compressor by rubber hoses.

### Air compressor

An **air compressor** provides the compressed air needed to operate pneumatic hand tools and equipment in the shop.

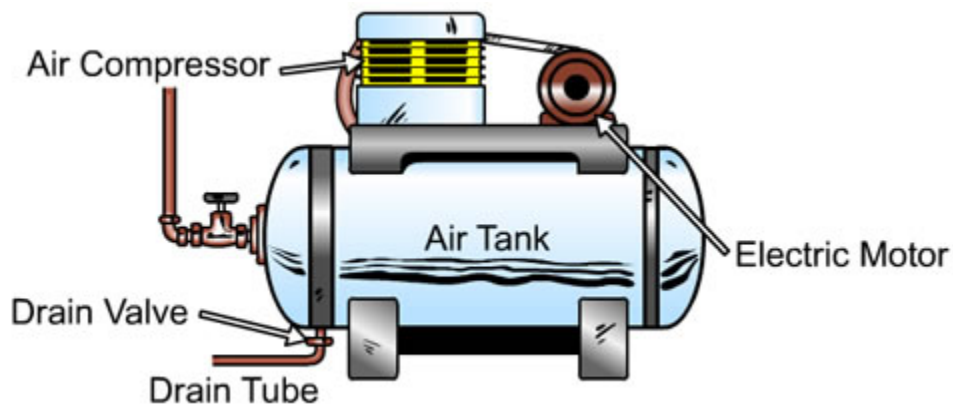

Compressors are usually operated by an electric motor and are composed of the following three main parts.

- Motor
- Compressor
- Storage tank

The motor drives a compressor that takes in the air around it, compresses it into a smaller volume (thus increasing pressure), and then stores the compressed air in a large storage tank.

### Maintenance

- Check the oil each week and maintain the oil at the proper level.

- Drain water from the tank and check the air-safety valve each day.
- Change the oil, check the belt condition and tension, and clean the air-intake breather per manufacturer's recommendations.

### Safety

- Always disconnect an air compressor from the power before inspecting or making adjustments to it.
- Before operating an air compressor, inspect its parts to make sure none are damaged.
- Make sure the electrical outlet for the air compressor is properly grounded.
- Water and oil can accumulate in air compressors. These should be drained daily. It is possible for compressed air to carry infection even with daily draining.

**CAUTION:** Do not play with compressed air blowguns or hoses. The high-pressure air stream on the skin can cause severe infection, require the amputation of a limb, and cause death.

- Air hoses should not be run over with vehicles or equipment and should not be used to pull tools across the shop floor.
- Air hoses should be kept free of grease and oil and neatly coiled for storage at the end of the workday.

### Tire machine

The **tire machine** uses great force to manipulate tires. Its uses include removing and reinstalling the tire onto the wheel and inflating the tire to the proper pressure.

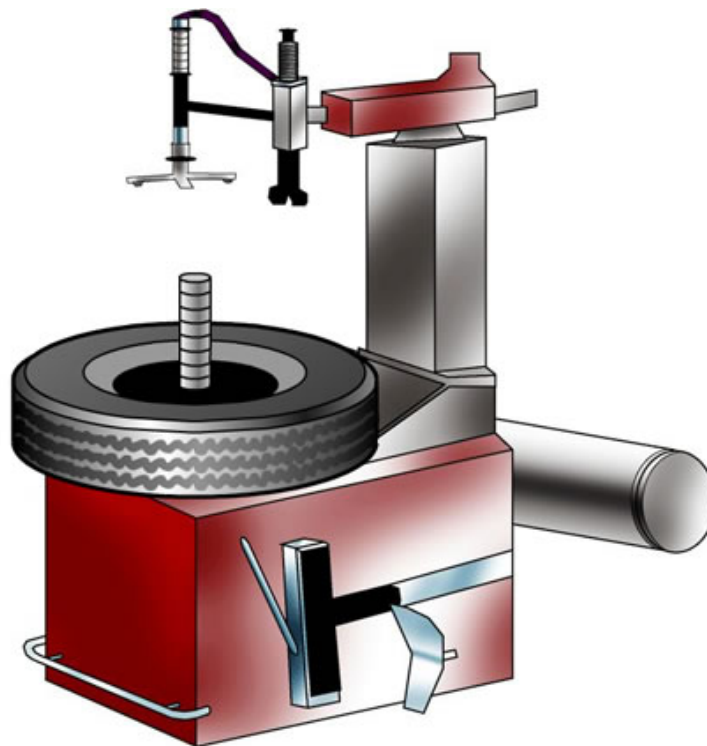

## Safety

- The tire machine is one of the most dangerous pieces of shop equipment. Do not use the tire machine without proper training.
- Truck tires that use the split rim type of mounting are very dangerous. These must be inflated in a special cage. Consult the instructor before attempting to mount a truck tire or any type of tire.
- Wear protective eyewear when working with a tire machine.

## Pneumatic jack

A **pneumatic jack** can raise a vehicle by the bumper or axle. Special instruction is required to use a pneumatic jack. The vehicle must be lowered onto safety stands before a technician can work under a vehicle supported by a jack.

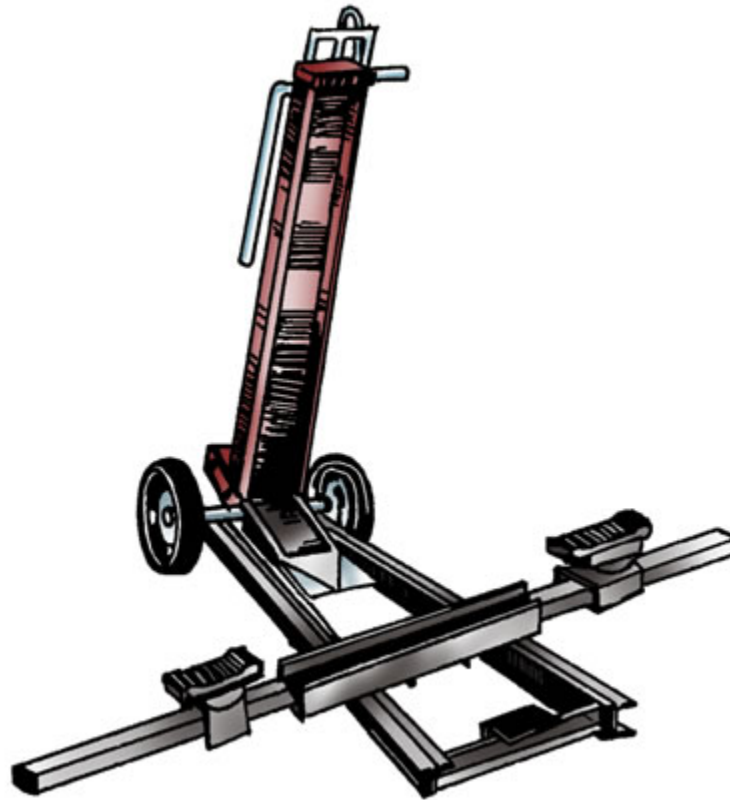

## Safety

- Never work under a vehicle supported only by a jack.
- Consult the instructor and repair manual when placing safety stands for the proper locations of the stands.
- Be sure that the load-capacity rating for the safety stands is sufficient to safely support the vehicle.
- Do not lift vehicles with passengers inside or with the doors, hood, or luggage lid open.

## General maintenance guidelines for pneumatic equipment

- Consult the maintenance instructions provided by the equipment manufacturer.
- Keep the piece of equipment free of dirt and grease and store it in an area that is dry and free of dust.
- Care should be taken that no foreign matter enters the nipple opening of the couplings on pneumatic equipment.

## Hydraulic Equipment

**Hydraulic equipment** develops pressure as a result of the closing of a valve and the pumping of a handle or as a result of a combination of air pressure over hydraulic fluid.

### Hydraulic floor jack

The **hydraulic floor jack** has a cylinder that raises the front, rear, or side of a vehicle by pumping a handle. A floor jack is mounted on four wheels for portability. It should only be used after thorough instruction. The vehicle must also be supported by safety stands.

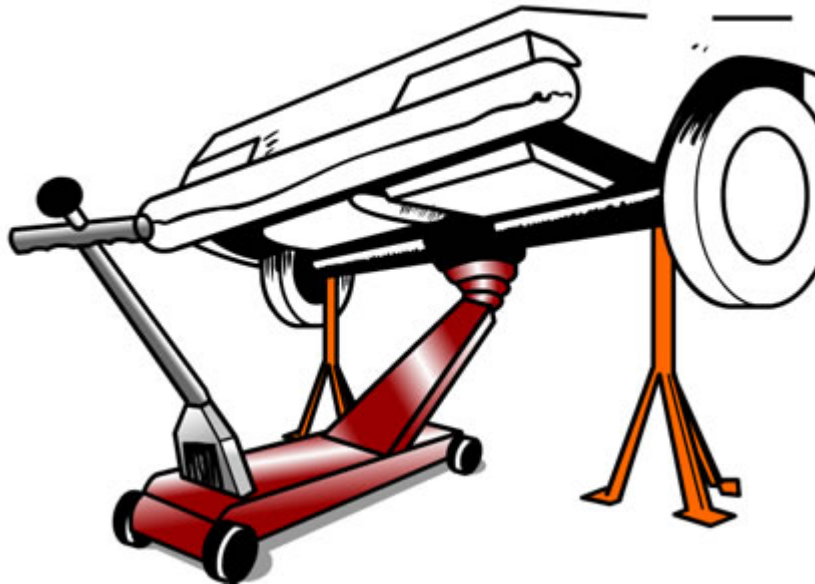

## Hydraulic lift

A **hydraulic lift** raises the entire vehicle off the ground. Most lifts use air pressure to pressurize hydraulic fluid, which is then pumped into one or more large cylinders.

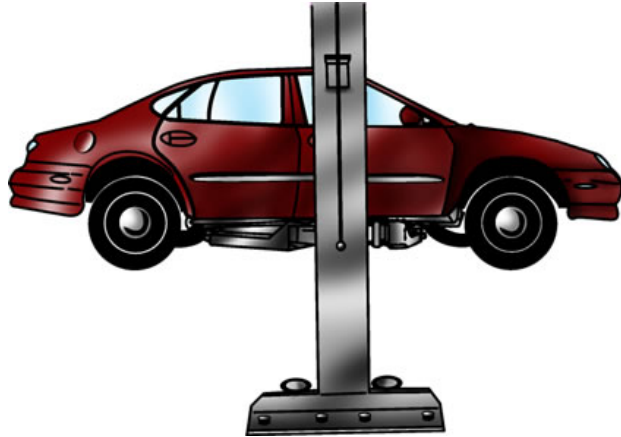

## Hydraulic press

A **hydraulic press** is found in most shops. It uses a powerful pushing force to press bearings and gears onto and off of shafts. Pulling a handle on the press raises or lowers a ram. The ram presses the part against a table.

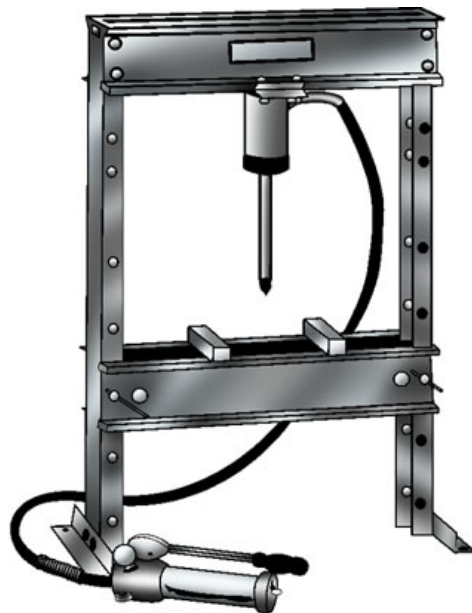

## Safety

- Consult the instructor for the procedure for properly setting up and using the hydraulic press.
- Wear personal protective equipment (PPE) while using a hydraulic press.



## Engine hoist

The **engine hoist**, or **portable engine crane**, is used to raise heavy engines and transmissions. After turning a valve, a handle is pumped to raise the hoist. A hoist is simply a hydraulic jack that is designed for attaching onto the top of an object and pulling it upward, instead of getting underneath of an object and pushing it upward.

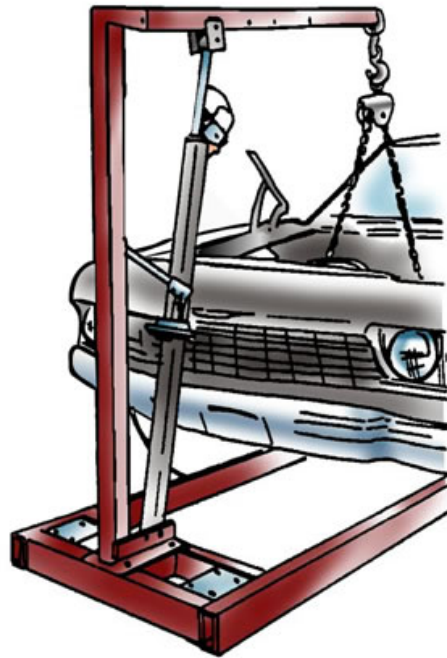

The engine hoist is not intended to support an engine while it is being serviced. The engine should be mounted on an engine stand during service.

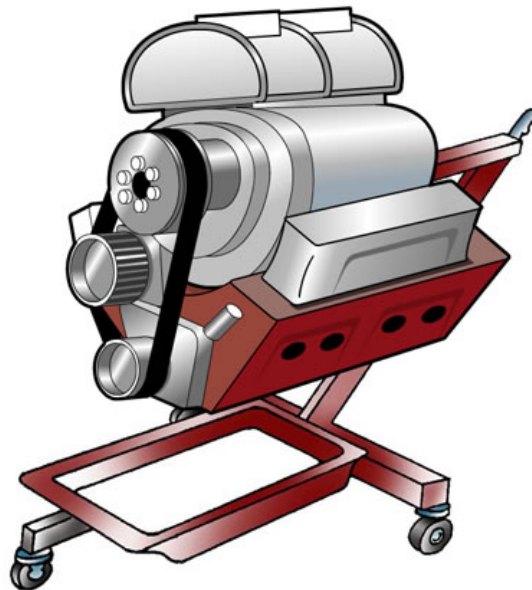

## **Safety**

- Consult the instructor before using the engine hoist.
- Stand clear of any object being raised in case the hoist fails or topples, or the object being lifted comes loose.
- When moving an object that is suspended from the crane, move the crane very slowly.
- Do not work on any object while it is suspended from the crane. Lower it to a workbench or the floor (or into an engine stand for a motor).

## **General maintenance guidelines for hydraulic equipment**

- Consult the maintenance instructions provided by the equipment manufacturer.
- Inspect equipment components and report any damage, leaks, or deterioration to the instructor.

## VEHICLE SERVICE INFORMATION

### Sources

**Note:** Vehicles have become so technologically advanced that service information is used on every job. This information contains diagnosis procedures, specifications, and service procedures. Technicians must know how to locate and use the information that is available.

Vehicle manufacturers publish service information for each model year of the vehicles they manufacture. This service information is the most comprehensive and the best source of information for a specific vehicle. It includes vehicle specifications, diagnostic and repair procedures, parts diagrams, and special tools required. Because many technical changes occur after the service information is published, manufacturers provide **technical service bulletins (TSBs)** to update the information. The information in the TSBs also appears in the next edition of the service information.

**Professional general service manuals** are used by independent repair shops because one manual can contain information for many domestic or foreign cars produced over several years. These books summarize the most important information and do not include all the specifics.

**Aftermarket specialty manuals** are often sold at bookstores and may cover one model of vehicle produced over several years. These manuals are written for individuals with and without experience in the automotive repair profession and are popular with the "do-it-yourself" individual.

An **owner's manual**, prepared by the vehicle manufacturer, is provided to the purchaser of the vehicle and is usually stored in the glove compartment. It includes basic information about the location and function of vehicle accessories, starting the vehicle, and maintaining the vehicle.

Sites on the Internet are available to find information that a shop may not have in its library, such as more up-to-date information, recall information, or information about a hard-to-diagnose repair issue.

### Formats

Besides printed manuals, service information is available for use on computer hard drives, networks, and CD-ROMs.

Using computerized information rather than printed materials saves space. In addition, accessing the information on a computer is easier and saves time.

## Using the Manufacturer's Service Information

Get familiar with the components of the service information and how they are organized. Doing so will help in finding information quickly. The general information section includes vehicle information such as identification (e.g., reading the **vehicle identification number (VIN)** to get data about the vehicle), basic maintenance, and lubrication. The repair sections, which cover each system of the vehicle, have detailed procedures for diagnosing, inspecting, testing, and repairing the systems. These sections also include the following features:

- Illustrations of exploded views of parts or steps in the procedure
- Diagrams showing the layout of hoses or circuits
- Diagnostic or troubleshooting charts for systematically finding the source of a problem

Before performing a procedure, read it through once to get an understanding and overview of what is required. Be careful to do all steps in a procedure and perform them in the correct order. Missing steps or performing them out of order may cause unsuccessful results.

## Locating and Reading the Vehicle Codes

In the early 1980s, the National Highway Traffic Safety Administration began requiring vehicle manufacturers to identify each vehicle made for highway use with a **vehicle identification number (VIN)**. A vehicle's VIN is a code with 17 characters (letters and numbers) that is permanently affixed to the vehicle. The VIN is typically found in several locations on a vehicle. Some of the more common locations are listed below.

- Dashboard near the lower part of the windshield on the driver's side
- Certification label on the driver's door frame
- Engine compartment

The VIN uniquely identifies a vehicle and provides a great deal of information about the vehicle's origin and features. See the sample VIN below for a breakdown of the code.

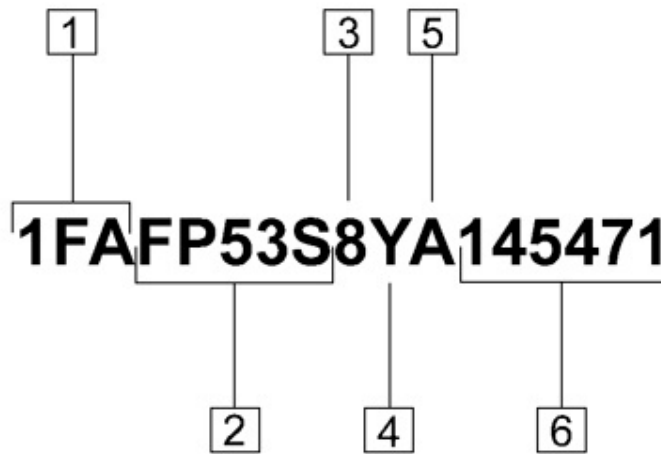

- 1 — Country and Manufacturer Identifier
- 2 — Line, Series, Body Type, Engine Type, Restraint System Type
- 3 — Check Digit
- 4 — Model Year
- 5 — Plant of Manufacture
- 6 — Production Sequence Number

For help in reading the VIN for a specific vehicle, check the general service information section of the service information for that vehicle.

An engine serial number and identification number or code is generally stamped on the engine block. The exact location of these numbers depends on the manufacturer. Engine codes provide technicians with specifications for the vehicle's engine, such as the horsepower rating and whether the engine was designed for a manual or automatic transmission.

## CUSTOMER SERVICE, WORK ORDERS, AND VEHICLE PREPARATION

### Proper Customer Relation Procedures

**Note:** Studies have shown that more people are fired for their inability to get along with others than for a lack of technical expertise. The behavior of the technician and other workers can jeopardize the financial stability of the shop.

**Note:** The amount and degree of customer contact required in an automotive technician position will vary depending on shop organization and policy.

All employees in the shop should greet the customer when appropriate and act in a friendly, courteous manner. Refer to the customer by using "Mr." or "Ms." and the person's surname.

Listen carefully and patiently. After the customer has explained the problem, ask questions that may help in the diagnosis. People communicate at different paces and in different styles.

**Note:** The customer is likely to be upset that the vehicle he or she depends on is unavailable and that the repair may be expensive.

- It is important to verify the complaint. Some customers unknowingly give a false diagnosis.
- Give the customer an estimate. A customer will likely be very upset if presented with a large repair that was not expected. Obtain the customer's phone number and call the customer before beginning the repairs.
- Look for potential problems other than those described by the customer. Explain any new problems to the customer in a professional manner.

**Note:** In most shops, the service manager/writer usually has the responsibility of calling the customer.

- Perform the repair in a professional manner. Remember that the customer is paying for a repair. The outcome of the job performed makes a statement to the customer and employer about the technician's skills and professionalism.
- Verify the repair. One of the most common complaints of vehicle owners is that they paid to have a repair performed only to experience the same problem after the repair was to have been made.

## Preparing a Vehicle Before and After Service

Another important part of customer service is making sure each customer's vehicle stays clean and free of damage during its time in the shop.

Place fender covers on the fenders, front grille, and other areas as needed to protect the vehicle from grease, scratches, and dents.



Use floor protectors to ensure dirt and grease from technicians' shoes do not soil the carpet.



Use seat covers to ensure that dirty or greasy hands and clothing do not soil the seats.





Cover the steering wheel with a steering wheel cover to protect it from greasy hands and fingerprints.



After service, follow the shop's policy on preparing the vehicle to return it to the customer. Some shops may require that all protective covers are removed, whereas others may want covers such as the floor protectors left in. Ensure that the customer's vehicle is as clean as when he or she dropped it off. Clean off any dirt or grease that may have gotten on the vehicle's exterior or interior.

## **Functions and Components of a Work Order**

The automotive technician should be familiar with the functions and components of a work order.

The work order serves several functions.

- Itemizes the repairs by listing the cost of parts and labor
- Can be used to authorize the repair
- Has the necessary information on how to contact the owner and serves as documentation for future reference
- May also specify limited warranties and liabilities of the shop
- May serve as a reference for recent service history for warranty or legal purposes

A work order typically has the following components.

- Customer name, address, and phone number (home or work with extension number)
- Date
- Invoice number
- Year, make, model, vehicle identification number (VIN), and mileage of the vehicle
- Name/initials of the service writer and technician
- Customer authorization signature to allow repairs
- Description of customer concern
- Vehicle service history information
- Related technical service bulletins (TSBs)
- Technician's notes that includes diagnostic procedures performed, the results of diagnosis, and any important observations or remarks
- Component or system defect responsible for the concern
- Service performed to successfully correct the concern
- Labor procedures and costs based on the parts and labor estimation guides
- Outside labor procedures and costs that include if a shop sent a particular part out to another shop for repairs
- Listing of each part that includes name, description, and cost
- Sales tax, which is usually calculated on parts only
- Total that represents the final price that the customer will pay for all charges related to the repair

Work orders may be handwritten or prepared by entering codes in a computer terminal and then printed.

Depending on the part, the following information may be required for ordering repair parts.

- Make, model, and model year (found on the driver's side door jamb) of the vehicle
- VIN
- Engine information that includes engine size, in cubic inches or liters, the number of cylinders, and the type of fuel system
- Wheelbase
- Number of doors

## Diagnosing a Vehicle Problem

Use the three Cs (concern, cause, and correction) to diagnose the vehicle problem.

Identify the concern. If possible, ask the owner/driver the following questions.

- Under what conditions does the problem occur?
- Are there unusual sounds?
- How long has the problem existed? Is it getting worse?

Test drive the vehicle under the conditions that the problem has been observed.

**CAUTION:** Always obtain instructor's approval before conducting a road test. Conduct the road test in an area with little or no traffic. Never exceed the legal speed limit during the road test. Always wear safety belts. An assistant should record all observations made during the road test. Do not attempt to drive and record results at the same time.

Isolate the cause of the problem.

Locate and interpret vehicle and major component identification numbers.

- VIN
- Vehicle certification labels
- Calibration decals

Research applicable vehicle and service information.

- Applicable components and their operation
- Vehicle service history
- Service precautions
- Technical service bulletins

Perform a visual inspection of the applicable system.

- Look for damaged or broken components.
- Look for worn or misaligned components.
- Check fluid levels.
- Inspect related electrical sensors, corrector, controls, and wiring.

Test the systems and components that could cause the problem. Eliminate good components until the cause is found.

Determine the necessary action and correct the problem.

## BRAKE SYSTEM FUNDAMENTALS

Automotive brakes are designed to slow and stop a vehicle by transforming **kinetic energy** (motion energy) into heat energy. As the brake linings contact the drums/rotors they create friction which produces the heat energy. The intensity of the heat is proportional to the vehicle speed, the weight of the vehicle, and the quickness of the stop. Faster speeds, heavier vehicles, and quicker stops equal more heat.

### Principles of Friction

Friction is the resistance to movement that results from two objects moving or rubbing against each other. There are two types of friction: kinetic and static.

**Kinetic friction** occurs between two objects, one of which is moving. Kinetic friction always produces heat. The more kinetic friction produced, the more heat produced. Automotive braking systems use kinetic friction to convert the energy of a moving vehicle into heat.

**Static friction** occurs between two objects that are stationary. Automotive braking systems use static friction to hold a vehicle while it is parked. Static friction produces no heat.

Various factors affect the amount of friction produced between two objects. The rougher the surfaces of two objects, the more friction they produce. Extremely rough surfaces create the most friction, but rough surfaces also wear down quickly. Therefore, automotive brakes use relatively smooth surfaces to avoid rapid wear. In order to compensate for their smooth surfaces, automotive brakes are applied with a great amount of pressure over a relatively large contact area.

The greater the pressure bringing the objects together, the more friction they produce. Therefore, the greater the pressure applied to the brakes, with all other factors equal, the greater their stopping power.

The greater the amount of shared contact area between two objects, the greater the amount of friction the objects produce. Automotive braking systems use the largest contact area possible. The greater the contact area of a brake shoe or pad, the less heat the shoe or pad generates. Less heat allows for more friction, which makes the brakes more efficient.

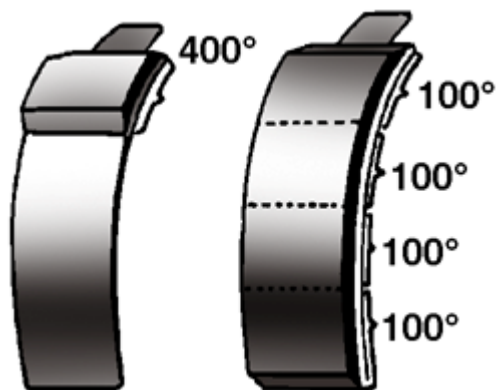

***The greater the contact area of a brake shoe or pad, the less heat the shoe or pad generates.***

**Note:** On **drum brake** systems, a **brake shoe** is applied to a brake drum to create friction. On **disc brake** systems, a **brake pad** is applied to a disc to create friction.

The hotter the friction surface of two objects, the less friction produced. (Rub your hands together and feel the heat!)

All heat that the brake system creates must dissipate as rapidly as it is created. The brake system can store little or no heat. Brake friction surfaces are made of a material that can conduct heat easily. Braking system components that produce friction (brake shoes or brake pads) are positioned so that air cools them. In some braking systems, forced air cools the components.

The amount of friction that two objects produce when rubbing against each other is called the **coefficient of friction**.

## Heat and Brake Linings

An important brake friction surface is the **brake lining** that is mounted on either a brake shoe or brake pad. The brake lining produces friction by directly contacting another friction surface, either a brake drum or disc. The brake lining and the material that it touches must have the following special characteristics.

The brake drum or disc must conduct heat easily, hold its shape under extremely high heat, withstand rapid temperature changes, resist warping and distortion, and wear well in general. Therefore, brake drums and discs are typically constructed of iron or steel combined with aluminum.

The brake lining must be somewhat softer than the brake drum or disc. At present, most brake linings are made of organic materials, metallic particles, and other minerals held together by a bonding agent.

**Note:** For years, asbestos was commonly used in brake linings. Because asbestos is a cancer-causing substance, federal law prohibits its use in brake systems.

When the brake lining is applied to a drum or disc, it is important that the proper coefficient of friction is produced in order to ensure that the brakes are effective.

- If the friction coefficient is too great, the brakes may be "grabby" or overly sensitive. Overly sensitive brakes may cause the vehicle to skid too easily.
- If the friction coefficient is too low, brake application requires excessive pressure. Applying the brakes with excessive pressure creates excessive heat that could result in brake failure.

**Note:** Heat always reduces the coefficient of friction between two objects. Hence, high temperatures may cause brakes to fail. The loss of brake effectiveness due to heat created during prolonged hard braking is called **brake fade**.

- If the brakes create more heat than they can dissipate, the friction coefficient reduces, which causes the brakes to fade.
- Excessive heat also causes bonding agents in the lining to melt and flow to the surface, which produces a glaze on the shoe lining. This glaze reduces the brake's friction coefficient

and causes more brake fading. Brake application then requires more pressure, thus creating more heat and more glazing.

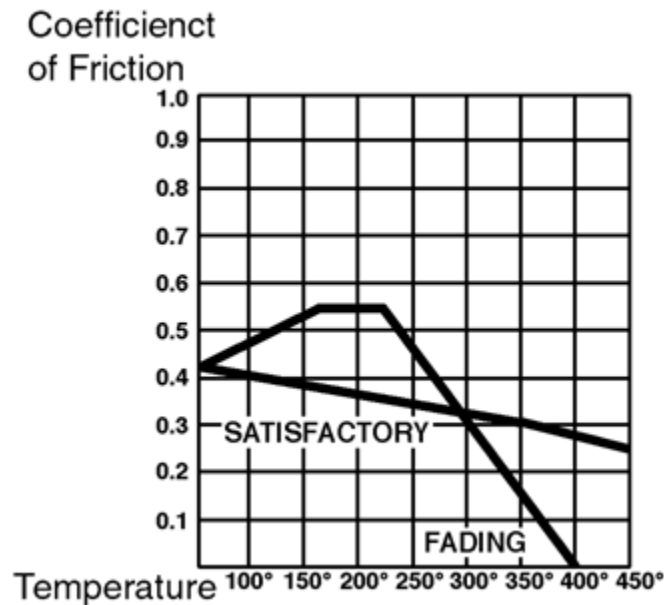

*The amount of friction that two objects produce when rubbing against each other is called the coefficient of friction.*

## Weight and Speed

### Vehicle weight

The more weight a moving vehicle has, the more kinetic energy it possesses. Brake systems must convert kinetic energy into heat; therefore, any increase in vehicle weight puts more demand on the brakes.

If a vehicle's weight doubles, the amount of kinetic energy that the brakes must convert into heat doubles. The amount of heat energy resulting from the conversion also doubles. Brakes on an overloaded vehicle may therefore become ineffective due to overheating.

### Vehicle speed

When the speed of a vehicle doubles, the brakes must convert four times the amount of kinetic energy into heat. Speed greatly increases the demand on a vehicle's brakes.

A combination of high speed and excessive weight may push a vehicle's brakes beyond their performance limit, resulting in a serious loss of stopping power.

## Friction Between Tire and Road

The point where a vehicle's tire contacts the road is called the **tire footprint**. Changes in the tire footprint affect a vehicle's ability to stop. Below is a discussion of the factors affecting the tire footprint.

The larger a tire's diameter is, the larger its footprint is. The larger the tire footprint is, the more stopping power can be applied at the tire's contact point with the road. However, it is important to realize that the greater a tire's diameter is, the more braking power is needed to stop the vehicle.

**Note:** A general rule is that the larger a tire's diameter is, the more braking power is required.

The greater the width of a tire is, the larger the tire footprint is. The larger the tire footprint is, the more stopping power can be applied at the tire's contact point with the road. However, it is important to realize that the greater a tire's width is, the more braking power is needed to stop the vehicle.

**Note:** A general rule is that wide tires require large brakes.

Excessive vehicle weight can distort tire tread and thereby reduce the tire's hold on the road. Tires that cannot hold the road reduce the vehicle's ability to stop.

High vehicle speed can aerodynamically lift a vehicle as it moves. This lifting reduces the tire's hold on the road and reduces the vehicle's ability to stop.

**Note:** Aerodynamic lift merely adds to the stopping problems that high speed creates. Remember that every time a vehicle's speed doubles, the vehicle's required stopping power quadruples, even if there is no aerodynamic lift.

**Note:** To control the vehicle, friction must occur at the tire footprint. If this friction is lost, the vehicle is out of control.

Tires grip the road more securely and can stop better if the wheels are moving. Therefore, the stopping power decreases if the brakes lock up the wheels. Automotive engineers carefully avoid designing brake systems that are too powerful for the cars in which they are installed. If a brake system locks up the wheels too easily, this significantly reduces stopping power and vehicle control.

## Service Brakes & Parking Brakes

Automotive brake systems fall into two major categories: **service brakes** (hydraulic brakes) and **parking brakes**.

Service brakes stop the vehicle when it is in motion.

A parking brake holds the vehicle while it is parked. A parking brake is not designed to stop a moving vehicle.

**Note:** Parking brakes often use the same friction surfaces as service brakes.

## Base Brake Components

Base brake components are the parts of the brake system found on all vehicles. The term "base brakes" does not include antilock brakes or traction control systems.

Base brake components include:

- Brake pedal and linkage
- Power brake boost system
- Master cylinder, hoses and pipes
- Brake rotors and pads
- Brake drums and shoes
- Brake balance controls (proportioning valve and metering valve), if equipped
- Red brake warning and other warning systems
- Parking brake pedal and linkage

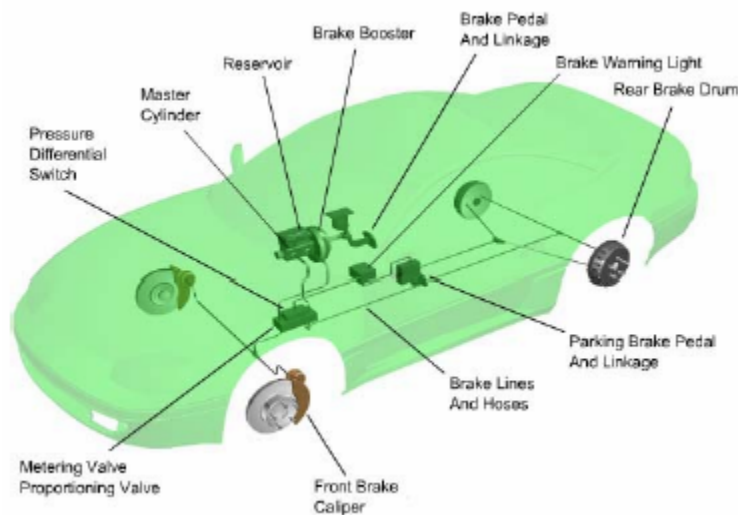

## Brake Subsystems

Automotive brake systems can be broken down into several different sub-systems:

- Apply system
- Boost system
- Hydraulic system
- Wheel brakes
- Balance control system
- Warning system



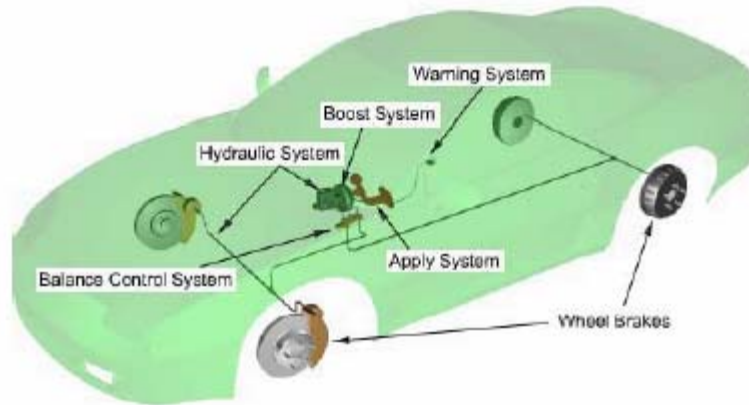

## Hydraulic Principles

An important principle of hydraulics is **Pascal's law of hydraulics**. Blaise Pascal was a French philosopher, mathematician, and scientist. Pascal's law of hydraulics states that when pressure is applied to a fluid in an enclosed space, the fluid exerts the same pressure equally in all directions.

If two cylinders are filled with liquid and connected by a tube, pressure from one cylinder transfers to the other.

Fluids are virtually incompressible.

When put under pressure, fluid does not compress or produce any measurable friction. Pressure does not diminish when transferred through fluid.

A second hydraulic principle states that a relationship exists between:

- Force and piston area
- Piston travel and piston area

From the first principle, if a master cylinder generates 500 psi, it also transfers 500 psi to the pistons in each wheel cylinder (remember that fluid pressure remains constant).

In the second principle, when pressure from a one-square-inch master cylinder piston exerts 500 psi on a wheel cylinder piston, which also has one-square-inch surface area, the wheel cylinder piston transfers 500 pounds of force to the brake shoe ( $500 \text{ psi} \times 1 \text{ in. sq.} = 500 \text{ lbs.}$ )

However, if the same one-square-inch master cylinder piston exerts 500 psi on a wheel cylinder piston that has a two-square-inch area, the wheel cylinder piston will transfer 1,000 pounds of force to the brake lining ( $500 \text{ psi} \times 2 \text{ in. sq.} = 1,000 \text{ lbs.}$ )

Additionally, different piston sizes not only affect the amount of brake force applied, they also determine the travel distance of the different pistons. For instance, if the one-square-inch master cylinder piston moves one inch, a one-square-inch wheel cylinder piston will also move one inch (with the same force).

If that same one-square-inch master cylinder piston moves one inch, then a two-square-inch wheel cylinder piston (twice the size) will move just one-half inch (half the distance) but with twice the force.

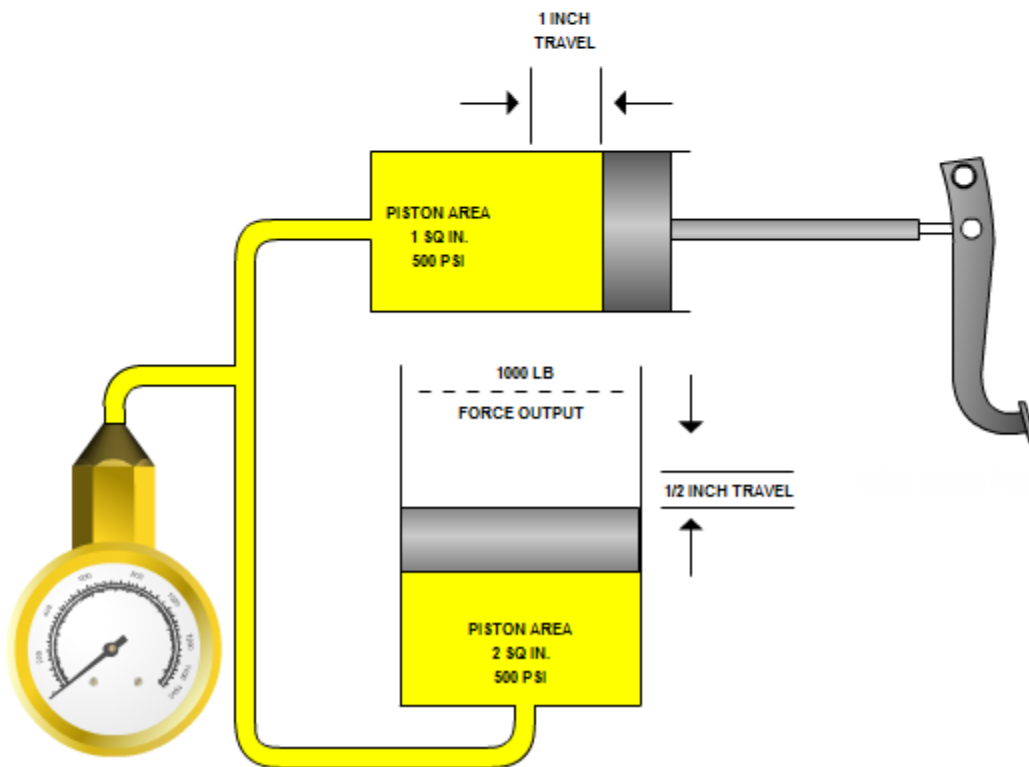
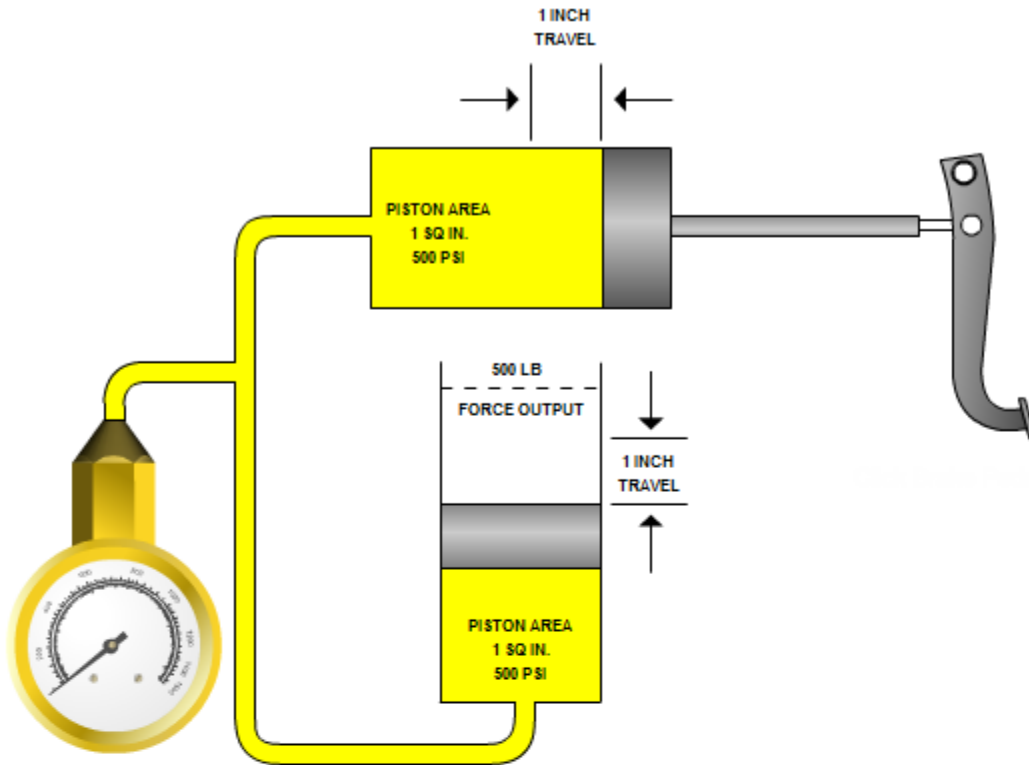

## Split Hydraulic Systems

Brakes are generally applied through force transmitted via a hydraulic system. The master cylinder converts brake pedal movement into hydraulic pressure to operate the brakes.

A partial loss of brake pressure makes it difficult or even impossible to apply the brakes. Therefore, federal law requires that all vehicles have two separate and independent hydraulic systems. In this way, the failure of one system will not result in a complete brake loss even though braking will still be severely reduced.

The two split systems used almost exclusively are:

- Diagonally split ‘ used on most front wheel drive vehicles
- Front/rear split ‘ used on most rear wheel drive vehicles

### Diagonal Split Hydraulic System

In a **diagonal split hydraulic system**, the left-front and right-rear brakes (LF/RR) are connected to one channel of the master cylinder while the right-front and left-rear brakes (RF/LR) are connected to the other channel of the master cylinder. This system is typically installed on front wheel drive vehicles because they have a front-heavy weight distribution and approximately 70% of the braking occurs at the front brakes. As such, if one part of a diagonal system failed, the overall braking would only be reduced to 50% rather than to 30% if both front brakes were lost. Diagonally-split systems also use proportioning valves either in the master cylinder circuits or in the rear brake lines to maintain the proper front to rear pressure balance. Proportioning valves will be covered in a later section.

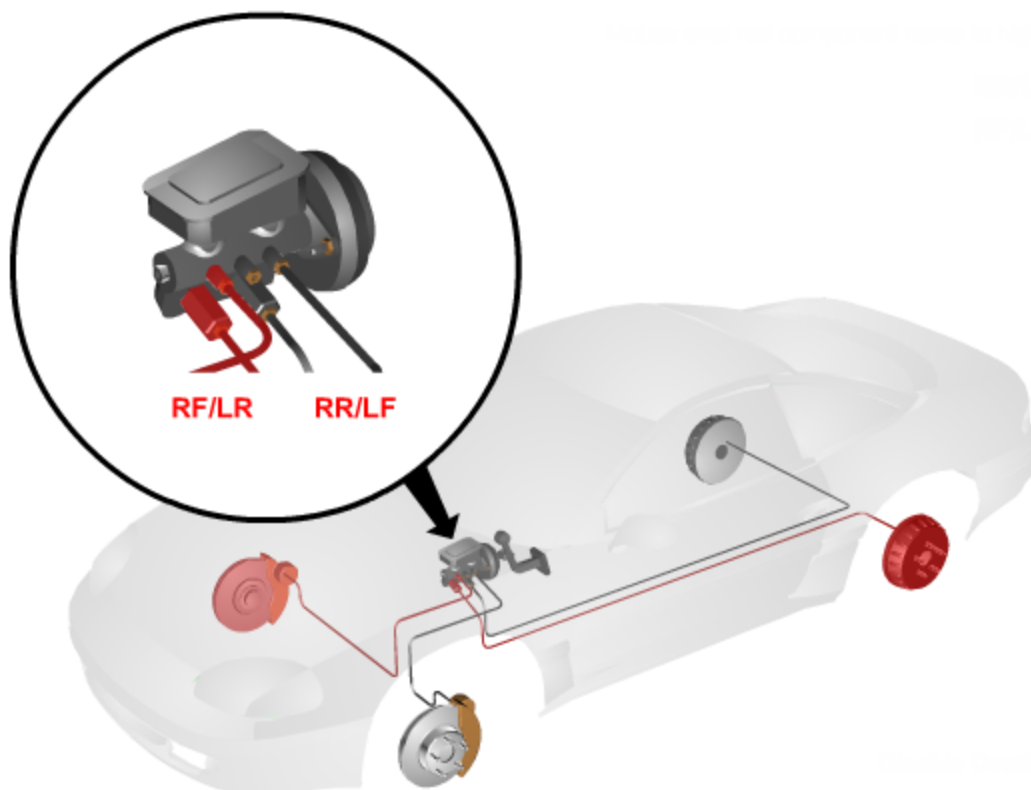

## Front/Rear Split Hydraulic System

In a **front/rear split hydraulic system**, both front wheel brakes work together on one system (channel) while both rear wheel brakes work together on a separate system.

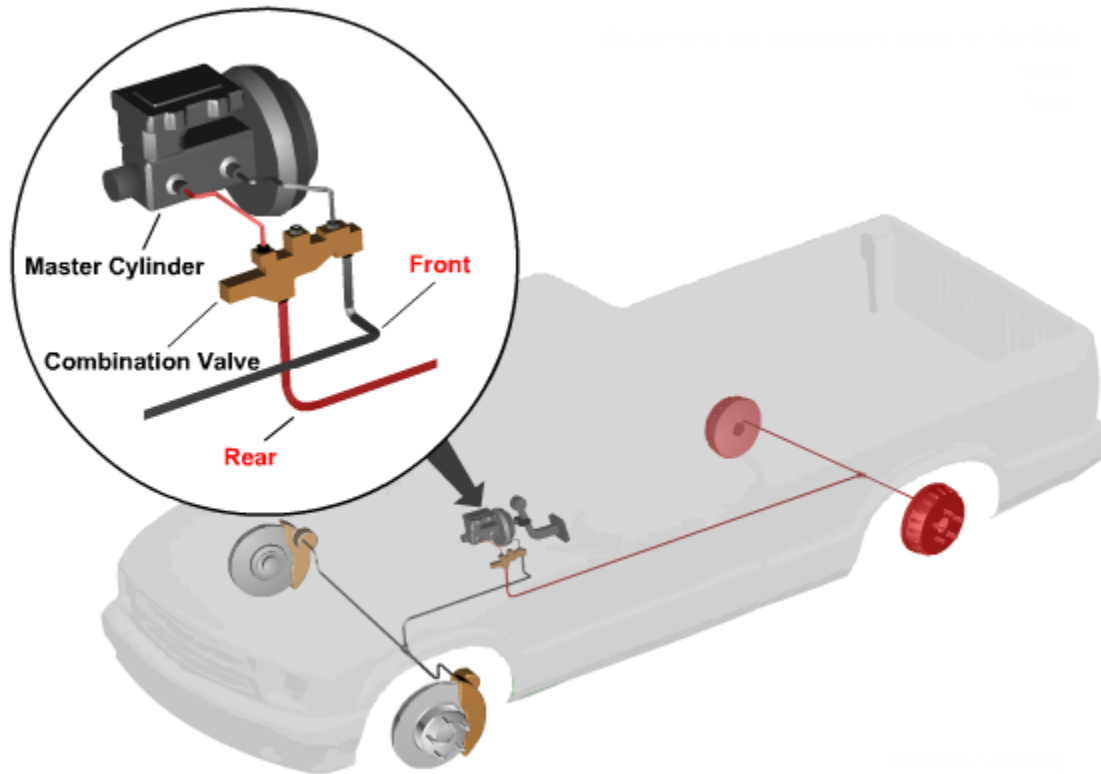

## Regenerative Braking

Hybrid vehicles use the kinetic energy of the vehicle in motion to generate electricity. The electric motor(s) that are used to power the vehicle become electrical generators when the vehicle is decelerating.

When the driver pushes the brake pedal, a signal is sent to the onboard computer(s), but instead of applying the hydraulic brakes, the electric motor(s) are used to slow the vehicle. The wheels of the vehicle drive the electric motors, which generate electrical current that is sent to the hybrid storage battery and stored for later use to power the vehicle.

In emergencies or high-speed stops, the vehicle's hydraulic brakes are used to slow the vehicle.

The components of the regenerative braking system include the onboard computer(s) used to control the hybrid and brake systems, the hybrid electrical motor(s), the hybrid electrical circuits, and the hybrid storage battery.

# ELECTRICAL FUNDAMENTALS

## Electrical Properties

Electricity involves three basic properties: **voltage, current, and resistance**. Each of these properties has its own unit of measurement: voltage is measured in volts, current is measured in amperes (or "amps"), and resistance is measured in ohms. Most students have no doubt used these terms and probably measured for them, but often they are used interchangeably even though they are in fact all different. To ensure that we are all talking about the same thing, a brief description of each is in order.

Another electrical characteristic you need to understand is **magnetism**. Magnetism, or electromagnetism, is caused by current flow through a conductor, and is the property that makes generators and starters work.

## Voltage

Voltage can easily be described as electrical pressure. A comparison to a household water hose will be useful in discussing voltage. If you have a water hose with a closed nozzle on the end and the spigot has been opened, there is water pressure in the hose even though no water is able to escape through the nozzle.

When there are more electrons in one place as compared to another (such as between the positive and negative plates of a car battery) there is said to be a "difference of potential" or voltage. The greater the difference between the number of electrons on one battery plate and the number on the other plate, the higher the voltage. A dead battery has the same number of electrons on the positive plates as on the negative plates. Batteries will be discussed in the following section.

The base unit for voltage is the "volt." Keep in mind that voltage is merely a "pushing" force and does not perform the real work in an electrical circuit.

## Current

Current is the movement of electrons in a circuit. In our voltage and water pressure analogy from before, current would be compared to the actual water moving through the hose. It is current, rather than voltage, which causes the motors to turn, the lights to shine, and the fuses to blow.

Voltage is defined as electrical pressure, and current is the flow of electrons through a conductor.

Unlike voltage, which is the presence of electrons, current is the movement of electrons through some sort of conductor. The greater the number of electrons past a certain point, the greater the current or amperage. The base unit for current is the "amp."

Various automotive electrical systems may use either a very high or a very low current. For instance, the starter system typically is high current, in excess of 100 amps, whereas spark plug current is very low (many confuse high voltage with high current in ignition coils) at much less than one amp.

## DC and AC

The current in any circuit will be one of two types: direct current (DC) or alternating current (AC). Direct current always flows in the same direction in a circuit. Alternating current flows in one direction, then reverses itself and moves in the opposite direction.

Batteries and other steady state devices produce DC, whereas alternators and wheel speed sensors produce AC. In order for a current to be AC, the current flow must actually change direction. The starting and charging systems, and the vast majority of automotive circuits operate on DC.

The automotive industry normally uses conventional flow theory. Most automotive circuits operate on DC. Remember that voltage is measured in volts, and current is measured in amps.

## Resistance

The base unit of measure for resistance is known as the "ohm" and is given the Greek symbol Omega ( $\Omega$ ). An ohm is defined as the amount of resistance that when applied to a one volt circuit, will limit the current to one amp. Thus, one volt through one ohm equals one amp.

Resistance is anything that opposes the flow of electrons. Resistance is measured in ohms.

Resistance is anything that opposes the flow of electrons. As the resistance in a circuit is decreased, the amount of current increases. As the resistance increases, the current decreases. Comparing this again to our water hose analogy, we find that if we use a larger diameter hose (less resistance) we will carry more water (more current). Conversely, a smaller hose (higher resistance) carries less water (lower current).

Resistance is affected by a substance's composition, the length and cross sectional area of the conductor, and temperature. A longer wire will have a higher resistance, and the larger the circumference of a conductor is, the less its resistance. For example, a 1.0 mm wire (16 Ga.) has less resistance than a .35 mm wire (22 Ga.). Also, as a substance is heated, its resistance increases (there are some exceptions to this rule).

Other factors also affect the resistance in a circuit, such as loose connections, corrosion, broken wire strands, etc. In contrast to the useful applications of resistance mentioned before, these will cause a circuit to operate inadequately or not at all.

## Shorts and Opens

A short circuit is a circuit that's "shorter" than it's supposed to be. Something provides an electrical pathway that shouldn't be there. A short to ground before a load will prevent the component (load) from operating, and cause the live part of the circuit to have insufficient resistance. This may cause excessive heat in the wiring, or cause fuses to blow. A short circuit across a switch may cause the switched component to operate when it is not supposed to, as will a short to power after a switch.

An open is an unintended break in a circuit. A common cause of an open is a broken wire.

## Voltage Drop

Voltage drop is very important in the diagnosis of electrical circuits. To explain voltage drop, let's return to our water hose analogy once again. At one time or another, we've all folded a hose in half to stop the water flow so we could relocate a sprinkler or as a joke on someone trying to wash their car. When that happens, the water pressure remains the same between the kink in the hose and the faucet, while the pressure on the other side of the kink is zero or almost zero. This difference is called the pressure drop and it is principally the same as in electrical applications. Voltage drop is then defined as **the difference between the voltage on the inlet side of a device compared to the voltage on the outlet side**. Comparing that value to a written specification will assist the technician in determining the fault with a system.

Voltage drop is the difference in electrical pressure between two sides of a device.

A DVOM can be used to check voltage drop, as well as many other starting and charging system tests. Other equipment also can be used to test batteries, starter current draw, and generator charging rate. These testers use a carbon pile or other resistor to place a load on the battery or generator. Testing methods will be covered in later sections.

## Battery and Starting/Charging System Test Equipment



Typical Starting and Charging Systems Tester

Several manufacturers produce specially designed units dedicated to testing batteries, and starting and charging systems. The carbon pile or resistor we have discussed is the distinguishing component of these machines. Pictured above is the Snap-on MT3750 model AVR, which uses a carbon pile. The control panel of the MT3750 is illustrated below.

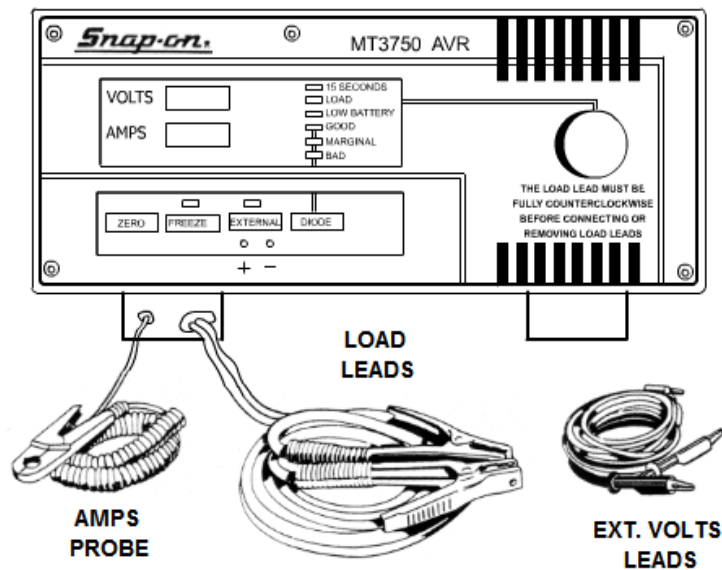

Machines of this type use an inductive amps probe, eliminating the need to break into the circuit for series starting and charging testing. The contacts of the inductive amps probe should be inspected periodically for dirt build-up, and to ensure the jaws close together fully. For best accuracy, place the probe away from strong magnetic fields such as those near generators or motors.



# AUTOMOTIVE BATTERIES

## Battery Function

An automotive battery is an electrochemical device that converts electrical energy into chemical energy and stores it until needed. When called upon, the battery converts the stored chemical energy back into electrical energy.

The battery serves four purposes in an automobile:

- It supplies electricity to the accessories when the engine is not running
- It supplies high current to the starter, and system voltage to the ignition system during cranking
- It provides current to the electrical systems when the demand exceeds the output of the generator
- It acts as a voltage stabilizer in the electrical system

Automobiles generally use what is classified as a wet cell, lead-acid battery. Batteries produce current through a chemical reaction between the active materials of the plates and sulfuric acid in the electrolyte.

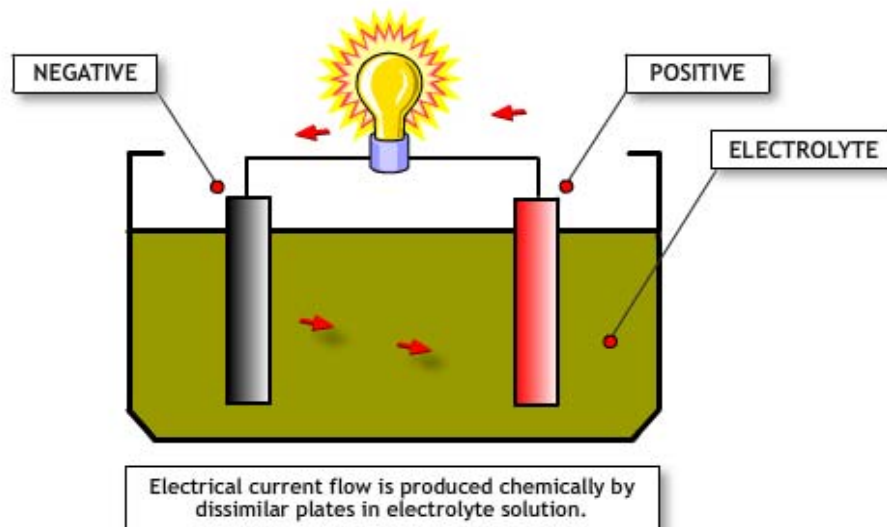

Throughout the life of a battery, it is either charging or discharging. When a battery is supplying current to accessories or to the starter, it is said to be discharging. When the engine is running at sufficient speed, the generator carries the electrical load and charges the battery, and both are said to be charging. A battery is discharging when:

Deep cycle batteries are designed to be more deeply discharged many times. While completely discharging an automotive battery does not ruin a battery that is in good condition, it may shorten the life of the battery.

- The engine is not running (parasitic loads or self-discharging)
- The engine is running at a low rpm with conditions of high electrical demand
- There is a fault in the charging system

A battery that is nearly or completely discharged is commonly said to be "dead," "flat," or "run down." A battery in this condition should be recharged to full capacity to provide proper service. Although a generator will charge a battery, it is not designed as a "battery charger." Requiring a generator to recharge a completely dead battery may cause overheating and damage to the generator.

Unlike "**deep cycle**" batteries used in some RV and marine applications, an automotive battery is designed to remain at or near a full state of charge, and not to be completely discharged.

## Battery Construction

A battery is made up of individual **cells**, electrically connected in series for a cumulative voltage effect. Each battery cell contains an element made up of positive and negative plates, separators, and connecting straps.

Each plate consists of a stiff mesh grid of a lead alloy, coated with porous lead on the negative plates, and lead peroxide or lead dioxide on the positive plates. A strap of lead connects the negative plates to form a group, and another strap connects the positive plate group. On each end of the battery, the straps are extended to form battery terminals or posts. The plates are submerged in an electrolyte solution.

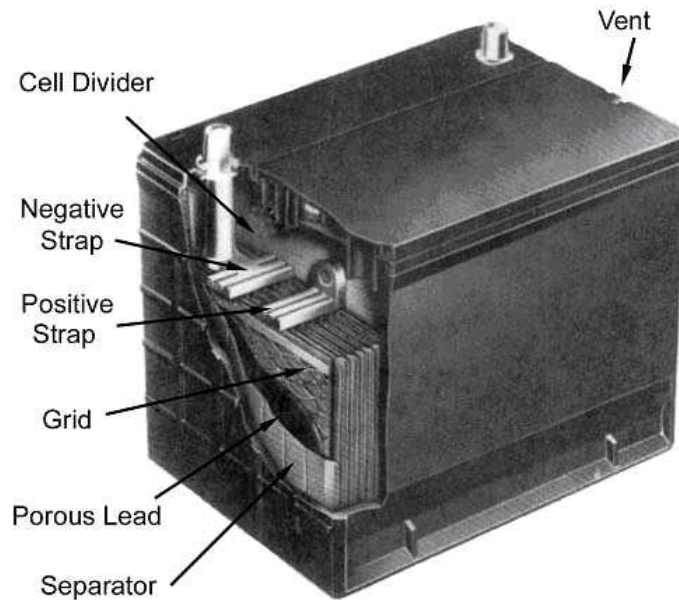

Acid fumes and water vapor are formed and released during the chemical reactions of charging. This **gassing** causes the loss of electrolyte. Conventional batteries have removable vent caps, permitting the electrolyte levels to be checked and topped off, as well as to allow chemical testing. "Maintenance free" batteries are designed to minimize gassing.



Some maintenance free batteries do not have removable covers or caps. Others do, to allow for the addition of water in case of overcharging or severe conditions, and to permit hydrometer testing. These batteries should not require additional water, but if the electrolyte **can** be checked, it **should** be checked approximately every six months.



**Conventional, Top Post Battery with Vent Caps Removed**

### **Gel Cell and Absorbent Glass Mat (AGM) Batteries**

Recent innovations in battery technology include gel cell, and absorbent glass mat designs. These designs do not have free electrolyte. Gel cell batteries were developed for use in mining equipment and have good resistance to shock and vibration.

In AGM batteries, the elements are compressed. The plates are thinner, allowing for more plates per cell. They are heat-resistant, and may last three times longer than wet cell batteries. The gel cell and AGM designs have not yet seen widespread usage, due to their higher cost

On some batteries, it may not be readily apparent that the cell covers are removable, so check carefully.

## Electrolyte and Specific Gravity

**Specific gravity** is a measure of the density or weight of a fluid, using water as a baseline. Water has a specific gravity of 1.000, and pure sulfuric acid has a specific gravity of 1.835, meaning it is 1.835 times heavier than water.

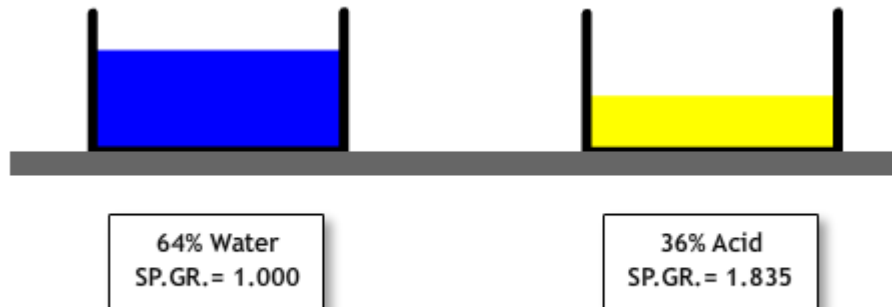

Electrolyte contains 64% water and 36% acid, which gives it a specific gravity of 1.265 to 1.270 in a fully charged battery (this is often expressed as "twelve seventy," etc.).

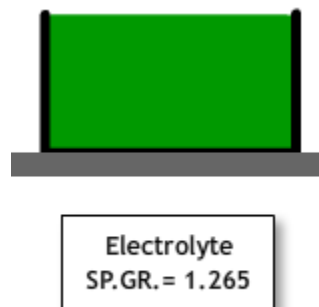

If the electrolyte is accessible, it can be checked with a **hydrometer**. As a battery is discharged, the electrolyte contains less acid and more water, so a hydrometer float will not rise as high in the hydrometer barrel, or fewer balls will float. Many maintenance free batteries have a hydrometer built into one of the cells. We will cover those, and hydrometer testing, later in the section. For now, keep in mind that the acid is heavier than water, and a discharged battery has more water in its electrolyte.

## Chemical Reactions while Discharging and Charging

In a fully charged battery, the active materials in the positive and negative plates is distinctly different in chemical composition, and the electrolyte has a high acid content. Positive plates contain a compound of lead and oxygen ( $\text{PbO}_2$ ), while negative plates contain lead ( $\text{Pb}$ ). The electrolyte is composed of water ( $\text{H}_2\text{O}$ ) and sulfuric acid ( $\text{H}_2\text{SO}_4$ ). Sulfuric acid is a compound of hydrogen, sulfur and oxygen.

As a battery begins to discharge, the composition of the plates becomes more similar, and the water content of the electrolyte increases. Lead sulfate ( $\text{PbSO}_4$ ) is formed on both the positive and

negative plates, trapping the oxygen and sulfur, and leaving water molecules behind (left side of illustration). The voltage potential of a battery is dependent on the dissimilarity of the active materials in the positive and negative plates. As the lead sulfate content in the plates increases, the voltage and available current decreases.

This process is reversed to charge the battery. Current applied to the battery causes the lead sulfate residing on the plates to release its oxygen into the electrolyte. This release increases the acid content of the electrolyte, and returns the plates to their original compositions (right side of illustration).

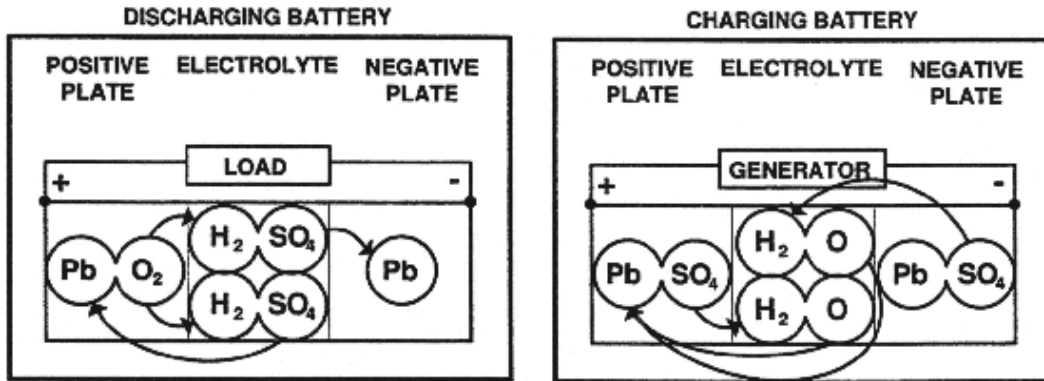

## Battery Safety

There are important safety concerns to keep in mind when working on or around automotive batteries. **Batteries can explode, and have enough power to arc weld.** Always respect the power of a battery, even a "dead" battery. **The sulfuric acid in electrolyte is extremely corrosive, and can cause severe chemical burns to the skin and eyes.** It will also damage painted surfaces and many other materials, including clothing. Always wear approved **safety glasses** when working around batteries and the use of **rubber gloves** is recommended when working with electrolyte.



You should know the locations of fire extinguishers and the first aid kit. First aid kits should contain a bottle of sterile, acid-neutralizing eyewash. Larger facilities often have an emergency shower and eyewash station located in the battery storage and service area.

Batteries release explosive hydrogen and oxygen gasses. A battery can explode with a sound like a shotgun discharging, rupturing the case and spraying acid in all directions. Avoid creating sparks around a battery. The following guidelines will help to reduce the chance of arcing or sparks:

- The ground terminal of a battery should always be disconnected **first** and reconnected **last**.
- Connect battery chargers to a battery **before** plugging in the charger.
- When jump-starting a vehicle, follow the proper procedure. **Do not** connect the jumper cable to the negative battery terminal of the vehicle you are jump-starting. The procedure to follow will be presented later in this section.
- **Do not** attempt to charge, jump-start, or load test a battery with a broken or loose post, a cracked case, or one in which the electrolyte is frozen.

**Accidental shorting of the positive battery terminal or any system voltage source to ground with a tool or metal object can cause severe burns.** Metal jewelry can be heated to its melting point in seconds. Even a brief short of this nature can damage the PCM and other electronic components.

**Never hammer on a battery terminal or cable end, or attempt to remove a cable by prying.** To avoid damage to the battery or terminals, and possible personal injury, use a clamp spreading tool if the clamp doesn't seat at the bottom of the post, and use a cable clamp puller to remove stubborn clamps. Avoid contact with the white, flaky or powdery corrosion that builds up around battery terminals and trays. This substance is sulfate and/or sulfide; it is corrosive and can cause chemical burns.

***Always follow all general safety guidelines for servicing motor vehicles with regards to adequate ventilation, working around hot or moving parts, proper use of parking brake, gear selector, wheel blocks, and disabling fuel or ignition systems. Refer to equipment User's Manual and vehicle Service Manual.***



## Battery Temperature and Efficiency

As temperatures fall, chemical reactions in the battery are slowed, and available power is reduced. At the same time, the current required by the starter to crank the engine increases, due to thickening of the motor oil.

- At 80° F, 100 percent of the battery's starting power is available
- At 32° F, 65 percent of the battery's power is available, but current draw may be increased to 200 percent of normal
- At 0° F, 45 percent of the battery's power is available, but the starting power required may be 300 percent of normal
- At -20° F, only about 20 percent of the battery's power is available, while the starting power required can be over 300 percent of normal

At this point, it is obvious that it is especially important to have clean, tight connections and a fully charged battery in cold weather. Keep in mind that cold temperatures have the same effect on charging rates, that is, it takes longer to recharge a battery in cold temperatures.

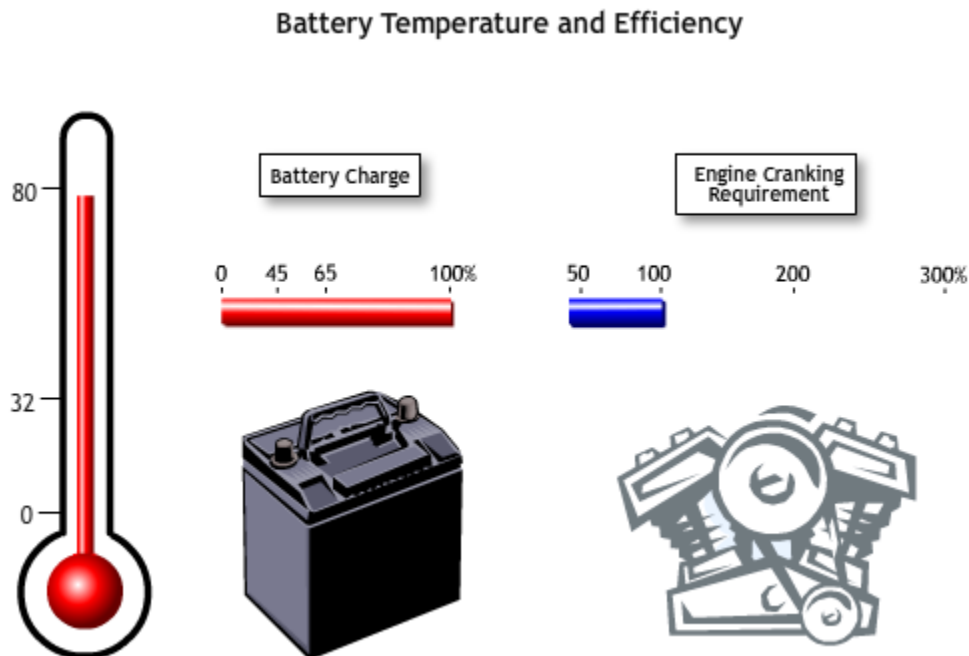



### Battery Temperature and Efficiency

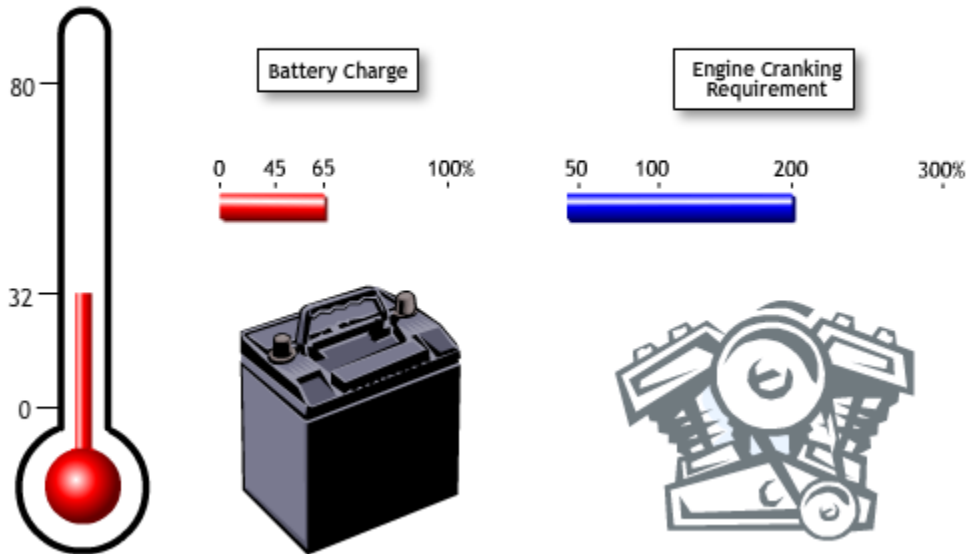

### Battery Temperature and Efficiency

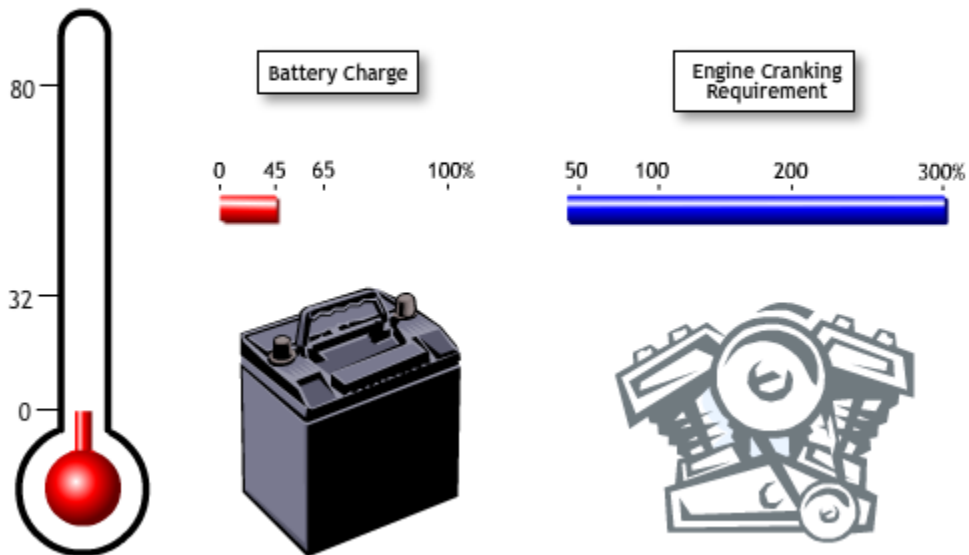

Excessive heat can also have an adverse effect on batteries. Batteries will self-discharge faster in a hot environment. In addition, higher-compression engines require more current to start when they are hot.

## **Battery Ratings**

### **Cold Cranking Amps (CCA)**

The Cold Cranking Amps rating indicates how much current (in amps) a battery can provide for 30 seconds at 0° F, while maintaining a minimum terminal voltage of at least 7.2 volts. This is the most important rating of a battery and it is used both in application specifications and in battery testing. The cold cranking rating is usually provided on a label or stamped into the battery case. Ratings from 350 CCA to 1000 CCA are common. The higher the number, the more powerful the battery, and the longer it takes to recharge.

### **Cranking Amps (CA)**

The Cranking Amps rating is similar to the Cold Cranking Amps rating, except the rated temperature is 32° F, instead of 0° F. Naturally, this will yield a higher number than the CCA. This rating may be useful in comparisons of cold weather operation between batteries.

### **Reserve Capacity (RC)**

The Reserve Capacity rating is the time (in minutes) required for a fully charged battery to reach a terminal voltage of 10.5 volts, at 80° F, when placed under a constant load of 25 amps. This rating is useful in determining how long a vehicle with a fully charged battery can travel at night with zero generator output. Typical ratings range from 90 to 200 minutes. The battery in a vehicle, with a charging system failure, will become too weak to start the engine before the reserve capacity is reached. It may, however, provide enough voltage to keep the spark plugs firing for a few minutes after this time. Reserve Capacity ratings usually appear on a battery's label.

### **Ampere-Hour Rating (AH)**

This rating has been largely replaced by the other ratings, but is still sometimes used to calculate recharging times. The Ampere-Hour rating is a measurement of how much current a battery can produce for 20 hours at 80° F without the voltage dropping below 10.5 volts.

# BATTERY CHARGE AND TESTING

## How Batteries Lose Power

Several factors contribute to the discharging or weakening of a battery. These factors may include:

- Normal aging
- Overcharging or undercharging
- Parasitic loads and phantom drains
- Self-discharging
- Inoperative or missing hold-downs

## Normal Aging

Any lead-acid battery will eventually wear out, due to normal cycling, overcharging, and undercharging.

A new battery that has never been in service has not yet developed its full power potential, although normal cycling soon brings the battery to its capacity.

The voltage difference between cells in a new battery is zero or negligible. As a battery ages, the voltage difference increases. When the voltage difference reaches .05 volts, the battery must be replaced. The cell with the lowest voltage will drain the other cells.

Load testing a new battery at its rated capacity may result in false test failures.

Years of cycling will finally take their toll on any battery. Small amounts of the active material on the positive plates are shed during cycling, and fall to the bottom of the battery. If the sediment at the bottom of the battery builds up enough to bridge the positive plates to the negative plates, a shorted cell will result.

## Overcharging

Overcharging, either by the vehicle's charging system or an external battery charger, speeds the shedding of plate materials, shortening battery life. Excessive gassing also carries away water from the electrolyte. In a sealed battery, the water cannot be replaced, and the battery will fail prematurely. In a conventional battery, the water can be replaced, but if the level is far enough below the tops of the plates to allow them to become dry, they harden and become chemically inactive.

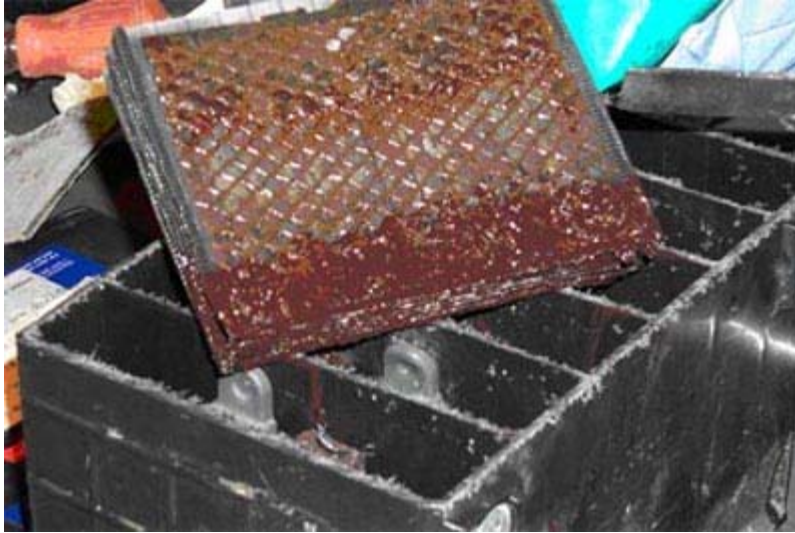

Overcharging promotes corrosion on the plates, and may cause the battery to heat up. Severe overcharging can cause a battery to swell, puffing the ends out noticeably.

A strong acidic or sulfurous smell may also be noticed.

Use care when working around a battery that has been overcharged as an overflow or residue of concentrated electrolyte is likely to be present. The battery tray and hold down should be cleaned and treated to prevent deterioration. A mixture of baking soda and water, or a commercially available treatment, are effective for this purpose.

**Shedding of Plate Material -- Overcharging has caused active material (brown) to shed from this plate, reducing capacity and powder. Note the exposed grid.**

### **Undercharging and the Result: A Sulfated Battery**

A battery that is less than fully charged is obviously not storing its capacity of energy. More importantly, it will be permanently damaged if left in this condition very long.

A battery that remains in a discharged condition for longer than approximately 30 days will begin to sulfate. Sulfating occurs when the lead sulfate on the plates crystallizes, becoming dense and hard, and difficult to break down. If the process has not gone too far, the battery may be restored to a serviceable condition by recharging at a reduced rate. A long, slow charge at half the normal rate may succeed in recharging the battery. A battery in this condition will not accept a normal charging rate and will simply overheat.

### **Parasitic Loads**

In modern vehicles, batteries are constantly being discharged by very small current loads needed to power the memory circuits of electrical devices such as electronic control modules and digital clocks. These are known as parasitic loads, because the circuits involved are always connected to the battery and continue to drain small amounts of current, even when the ignition is turned off. One or more control modules may, at some time, exhibit a failure mode that causes a high parasitic drain. The total parasitic draw for a particular vehicle varies according to the level of electrical equipment on the automobile. For example, a fully equipped luxury car would normally have a much greater

parasitic draw than a smaller economy car. The table shows examples of typical parasitic draws, measured in milliamps (mA), for various automotive components.

Component	Typical Milliamp (mA) Draw
Adaptive Lamp Motor	0.5
Blower Control Module	1.0
ELC (After 7 Minute Time Out)	0 to 1.0 max
Electronic Brake (& Traction) Control Module After 4 Minute Time Out	1.0
Generator	2.0
Heated Seat Control Module (LH/RH)	0.5
HVAC Programmer	0.5
Instrument Panel	4.0
Digital Cluster	4.0
Gages Cluster	4.0
Lamp Control Module	0.5
Oil Level Module	0 to 0.1 max
PCM	5.0
Pull-Down Unit	1.0
RAC Module (Retained Accessory Power) (Illuminated Entry) (Remote Keyless Entry)	0 to 3.8 max
Radio	7.0
CD	1.8

Parasitic draw can be measured by connecting an ammeter in series with the battery, or by using an ammeter with an inductive pickup that closes around a battery cable. All of the leads going to the battery terminal must be enclosed in the probe. The inductive amps probe on starting and charging test equipment is typically accurate to only about .1 amps, so in most cases an ammeter in series, accurate in the milliamps range, is needed.

Current draw from 5 to 30 milliamps is usually considered normal parasitic draw; however, some RV applications may have a normal parasitic load of up to 60 milliamps.

To properly test for parasitic loads with an ammeter connected in series requires a special tool. The tool maintains continuity through the system until you are ready to take the reading. This is necessary because current drain may not occur after the battery is disconnected to install an ammeter. Cycling the ignition key to the RUN and then to the OFF position may cause the drain to recur, but there may be drains that will not recur unless the vehicle systems are reactivated in a road test. **The key must not be turned to the START position with an ammeter installed**(except with a high-current shunt installed, such as when checking starter draw). The special tool does enable the vehicle to be driven to assure that all systems are ready for testing.

When using a hand-held DVOM, be sure to use the highest amperage range to prevent blowing the meter's fuse in a lower range range. Furthermore, be sure not to cause a current overload by opening a door (courtesy lights) or by any other means with the tool in the OFF position. When testing is complete, turn the special tool to the ON position (continuity through battery cable) to guard against current overload, **and never turn the tool to the OFF position with the vehicle's engine running.** To do so could damage the meter and the vehicle's electrical system.

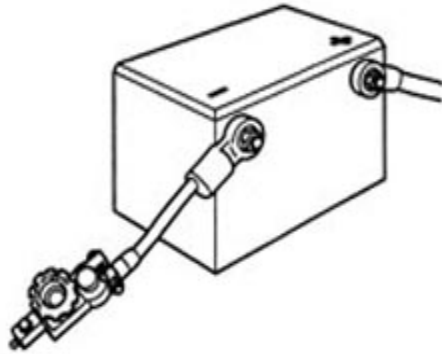

**Special Tool**

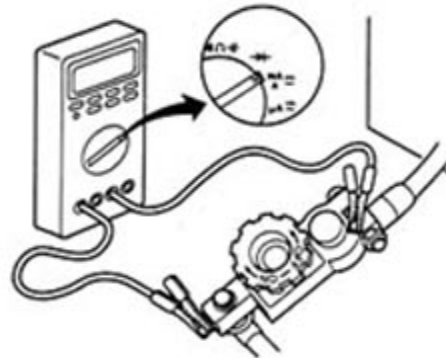

**Parasitic Draw Test**

Any time the battery is disconnected from the system, you may want to use a **memory saver**. This device plugs into the vehicle cigarette lighter receptacle, and provides voltage to the system when the battery is disconnected. Using a memory saver will prevent driver-programmed information from being lost (radio station presets, clock, etc.) as well as possibly avoiding driveability problems associated with the control modules having to relearn information. It can take up to one hundred miles of driving to relearn everything (ideal ignition timing, injector pulse width, etc.) and operate normally.

The service manual provides the procedure for Battery Electrical Drain/Parasitic Load testing using an ammeter in series, and the special tool. **Follow the procedure exactly**, to avoid damage to the vehicle or meter.

## **Phantom Drains**

A phantom drain is an abnormal parasitic load caused by a component such as a trunk or glove box light bulb that stays on all the time. This can be caused by misadjustment, a bad switch, or a short. A phantom drain can draw up to several amps, and will discharge the battery faster than a normal parasitic load.

Once it has been established that there is an excessive parasitic load, the problem can be isolated by pulling fuses or disabling circuits until the circuit causing the drain is identified. The fuse is then replaced and each component on that circuit is checked one at a time until the trouble is isolated. It may be necessary to remove the fuse for the interior lights so the doors can be opened.

## Self-Discharging

When a battery is stored, a slow chemical reaction causes the battery to self-discharge. A significant amount of power is lost after one month, and after four months of storage at 80° F, a battery can be 50% discharged. For this reason, stored batteries must be recharged periodically, **before** they become significantly discharged.

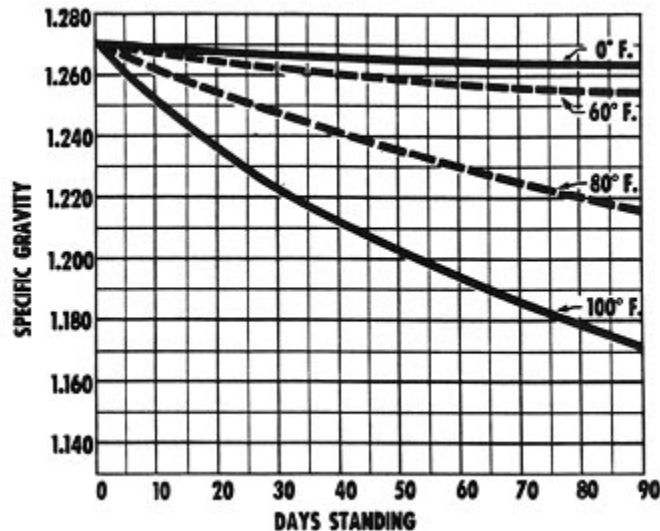

## Self Discharge Rates

Cold temperatures, on the other hand, slow the rate of self-discharge. A battery can be stored at 0° F for an extended period without self-discharging.

Dirt and/or electrolyte residue between the battery terminals can speed self-discharging. Current can track across the residue, to ground, so the area between the terminals should be clean. This is more prevalent with top post batteries.

Contrary to popular myth, setting a battery on a cement or concrete floor has no effect on the rate of self-discharge.

## Inoperative or Missing Hold-Down

Many batteries fail prematurely due to an inoperative or missing hold-down. It is very important that the hold-down be securely tightened, and that the tray is intact and holds the battery level. Without the hold-down, the battery can slam into other components and suffer internal or external damage. In some cases, the battery can even tip over or contact a metal object and short out. Because of the strong chemical reactions in the battery, the battery tray and nearby components are prone to corrosion. Most applications now use trays and hold-downs made of corrosion-resistant materials.

## Corrosion

Corrosion forms on and around the battery cable ends, between the cable ends, on the battery terminals, and inside the battery. The positive terminal is particularly susceptible to corrosion build-

up, which can creep down the cable where it is not visible. Look for a swollen cable or discolored insulation.



**Corrosion --The positive terminal of this battery corroded so badly it became fused to the cable and broke. Note the internal corrosion on the strap and plates.**

When corrosion builds up between the points of contact, it creates excessive resistance to current flow and can prevent starting and proper charging. This type of bad connection may allow small amounts of current to pass, but not the larger current needed for starting.

For best battery performance and longest life, the cables should be disconnected, cleaned, and inspected about once a year. Excessive corrosion can be removed and neutralized with a baking soda and water solution. Battery terminals and cable ends should be cleaned with a battery terminal brush. The surface of the cable end that mates to a side terminal battery is prone to a build-up of very hard, bluish-white sulfide. All of this stubborn corrosion must be removed. The use of a small screwdriver or awl may be necessary. After reconnecting, the cable ends can be protected with a light coating of petroleum jelly or wheel bearing grease.



**Battery Terminal Brush**





Cleaning Terminals with a Terminal Brush



"Universal" terminals are not recommended

**Note:** Avoid replacing corroded cable ends with units that splice to the end of the cable. These invite corrosion at the splice. The splice also tends to come loose and cause a poor connection. Replace the cable, if at all practical.

## Battery Testing and Service

There are several methods for determining the condition of a battery. A battery that fails these tests can often be condemned immediately.

Electronic battery testers that run a series of tests on a battery are available. These testers are simple to use, and can determine the condition of batteries without having to take the time to recharge them. However, these testers may return a result of "Charge and Retest." This means the battery is insufficiently charged to be tested. **A battery must be fully charged in order to be accurately load tested.**

### Initial Assessment

Battery testing begins with a visual inspection of the battery, connections, and cables. A battery with a cracked case, broken or loose posts, or a sealed battery with insufficient electrolyte must be replaced. **No testing is necessary;** do not attempt to test such a battery. During your visual inspection, also note the general condition and age of the battery.



Battery Condition - This battery is leaking from a loose positive post and should not be tested. The battery is finished.

Despite marketing claims, many batteries do not last the length of their extended, prorated warranty period. The normal lifetime of most batteries is from three to five years.

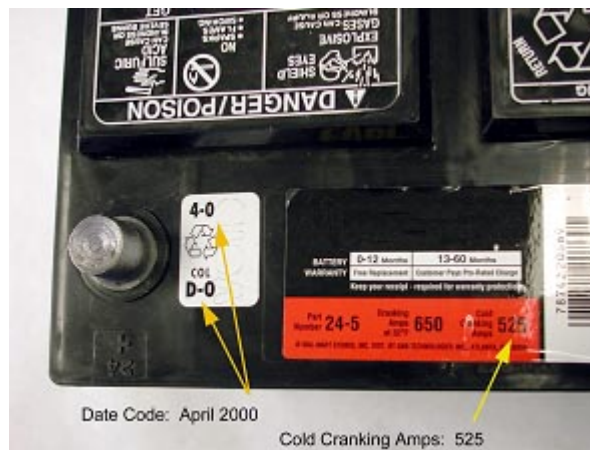

Battery Information

The date of manufacture is stamped into the battery case, and/or punched out of the label.

Most manufacturers use a date code with a letter corresponding to the month, and a number corresponding to the last digit of the year. For example, a date code of "A-1" means the battery was produced in January of 2001.

## Open Circuit Voltage

Open circuit voltage is the voltage in a battery without any loads connected. Checking the open circuit voltage will give you a quick check of a battery's state of charge.

Remove the surface charge by turning on the headlights for one minute, then connect a voltmeter across the battery. The reading should be 12.6 volts or more for a fully charged battery.

A weak or discharged battery is often a symptom of a problem elsewhere in the vehicle. Regardless of the testing method used, be sure the battery is bad, and not merely discharged before recommending a replacement.

## Hydrometer Testing

Hydrometers are used to measure the specific gravity of electrolyte. A hydrometer with a single float and a numerically graduated scale is recommended. This type of hydrometer usually has a built-in thermometer to make necessary temperature corrections. Smaller hydrometers that use multiple, colored balls are generally not reliable. The hydrometer pictured is a Snap-on BB4A.



Battery Hydrometer

**Hydrometer floats and barrels are made of thin glass and are fragile. Handle with care!**

This chart shows the charge level and voltage for specific gravity readings taken with a hydrometer.

<u>Charge Level</u>	<u>Specific Gravity</u>	<u>Voltage (12)</u>	<u>Voltage (6)</u>
100%	1.270	12.60	6.3
75%	1.225	12.45	6.2
50%	1.190	12.24	6.1
25%	1.155	12.06	6.0
Discharged	1.120	11.89	6.0

Charge Level, Specific Gravity, and Voltage

## Built-In Hydrometers

Many maintenance free batteries are equipped with a built-in hydrometer. Hydrometers will indicate the state of charge in only one cell of the battery, and therefore have limited diagnostic value. The built-in hydrometer contains a ball (usually green) and a round sight window or "eye" on top of the battery. Information on interpreting built-in hydrometer readings is printed on the top of most batteries. Wipe the window clean and look straight down at it in sufficient light. The eye will appear green, dark, or yellowish.

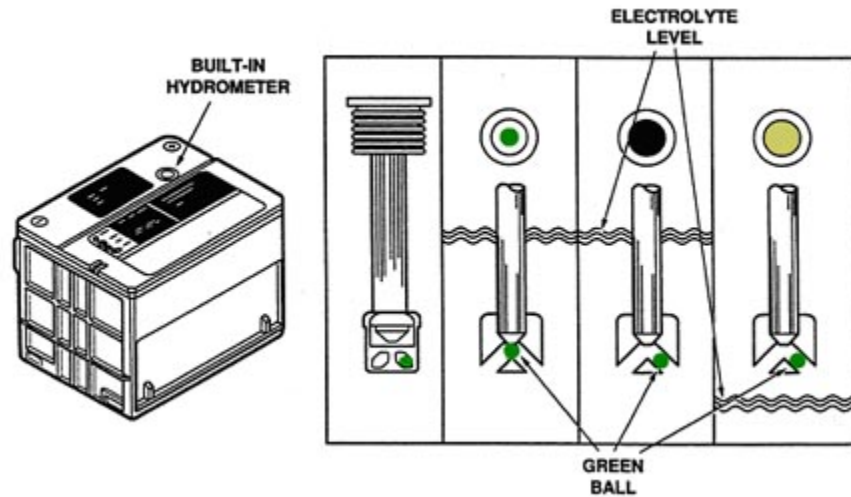

Built-in Hydrometer

- **Green eye** – The battery is charged to at least 65% of its specific gravity. Some battery manufacturers consider this sufficient for testing.
- **Dark eye** – The ball is not floating high enough to be seen, indicating the battery is less than 65% charged. This does not necessarily mean the battery is bad, merely discharged. The battery may be tested with an appropriate electronic tester, but results may be inconclusive. The battery must be recharged in order to perform conventional load testing.
- **Yellowish eye (clear)** – The electrolyte level is low; replace the battery. Sometimes a gas bubble will cause a false yellow reading. Tap the hydrometer lightly with a small screwdriver handle or shake the battery gently and check it again. **Do not attempt to charge or load test a battery with a yellow eye.**

## Conventional Hydrometers

A conventional hydrometer works like an eyedropper or a turkey-baster. The battery caps are removed, and the bulb is squeezed before immersing the pick-up tube in the electrolyte. When the bulb is gently released, electrolyte fills the tube, and the float rises to a certain level, indicating the state of charge of the cell. A reading is taken and noted, and each cell is checked in this manner.



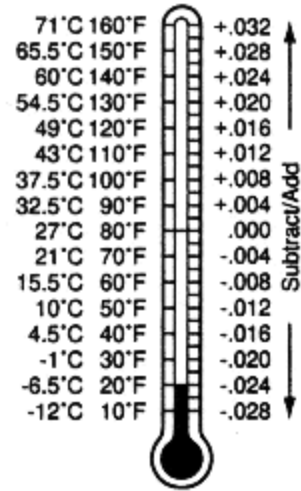
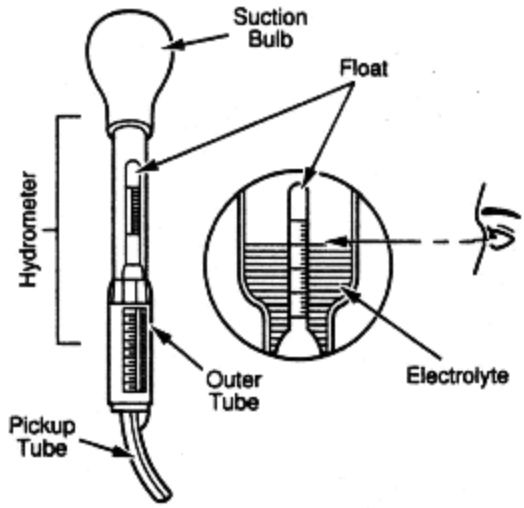

**Example:**  
 Electrolyte Temperature ..... 40°F  
 Hydrometer Reading ..... 1.250  
 Subtract Specific Gravity ..... -0.016  
 Corrected Specific Gravity Equals ..... 1.234

**Example:**  
 Electrolyte Temperature ..... 100°F  
 Hydrometer Reading ..... 1.240  
 Add Specific Gravity ..... +0.008  
 Corrected Specific Gravity Equals ..... 1.248

**A Fully Charged Battery Has a Specific Gravity of 1.270.**

Hydrometer and Temperature Correction

Here are some guidelines for using a hydrometer:

- Remember – electrolyte is acidic. Be careful, and avoid allowing the hydrometer to drip. Release the electrolyte back into the battery **slowly**.
- The float should be lifted free, and not touch the sides or bottom of the barrel.
- Take the reading with your eye level to the surface of the fluid.
- If there is a difference of .050 between the lowest and highest readings, or if all readings are below 1.225, recharge the battery.
- If, after recharging the battery, there is still a .050 difference between the highest and lowest reading, or there is still a reading below 1.225, replace the battery.
- If the battery passes this test, proceed with a load test.

Frequently, five cells will show good readings in the 1.250 to 1.270 range, with one cell showing a very low reading or not moving the float at all. Commonly called a "dead cell," this usually indicates a short. No further testing is necessary; the battery must be replaced.

**Drawing Electrolyte into the Hydrometer**

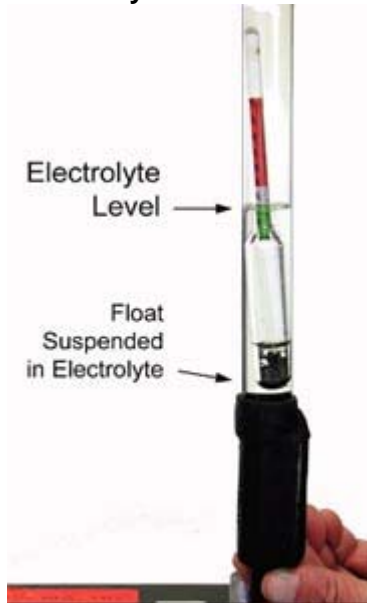

**Notice how buoyant the float is in this fully-charged battery**



**The next cell is checked, and also reads good: 1.265. However...**



...the last cell doesn't move the float at all.



The reading is below 1.100. When compared to the other readings, this indicates a bad cell.

## ENGINE OVERVIEW

The engine is the power plant of a vehicle. Automotive engines have gone through tremendous changes since the automobile was first introduced in the 1880s, but all combustion engines still have three requirements that must be met to do their job of providing power – air, fuel, and ignition. The mixture of air and fuel must be compressed inside the engine in order to make it highly combustible and get the most out of the energy contained in the fuel mixture. Since the mixture is ignited within the engine, automobile power plants are called **internal combustion** engines. Most can be further classified as **reciprocating piston** engines, since pistons move up and down within cylinders to provide power. This up-and-down motion is converted into turning motion by the crankshaft.

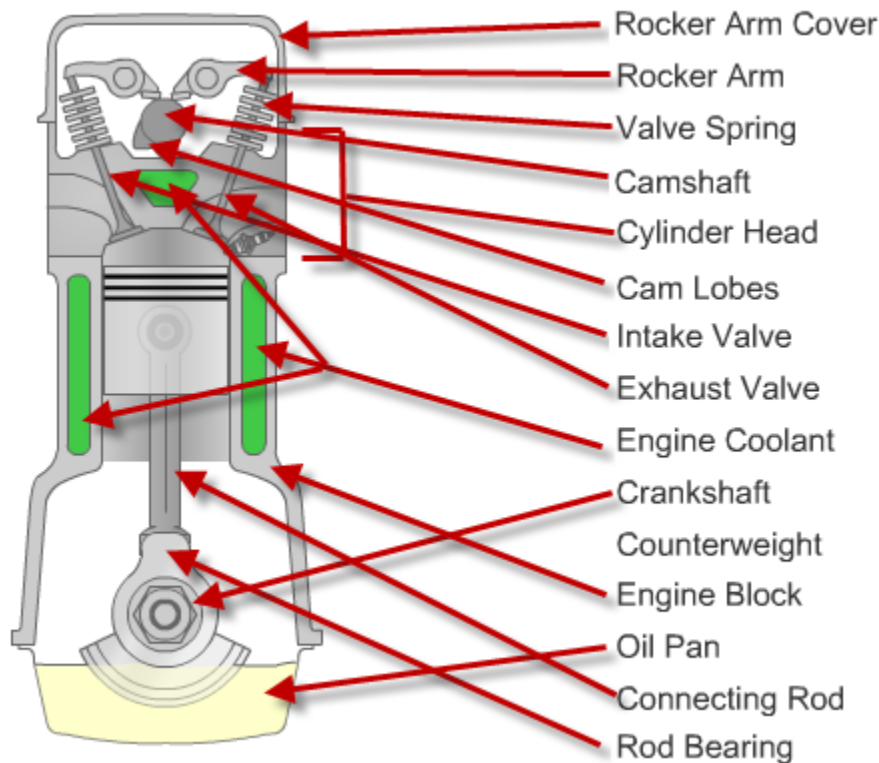

## Basic Engine Parts and Operation

A small engine, such as one found in a lawn mower, usually contains only one cylinder and piston. Automotive engines use a number of cylinders to produce sufficient power to drive the wheels, but operate much like a small engine in many ways. Let's look at one cylinder of an engine to see how the main parts work together.

**Engine Block** – The block is a heavy metal casting, usually cast iron or aluminum, which holds the lower parts of the engine together and in place. The block assembly consists of the **block, crankshaft, main bearings and caps, connecting rods, pistons**, and other components, and is referred to as the **bottom end**. The block may also house the camshaft, oil pump, and other parts. The block is machined with passages for oil circulation called **oil galleries** (not shown) and for coolant circulation called **water jackets**.



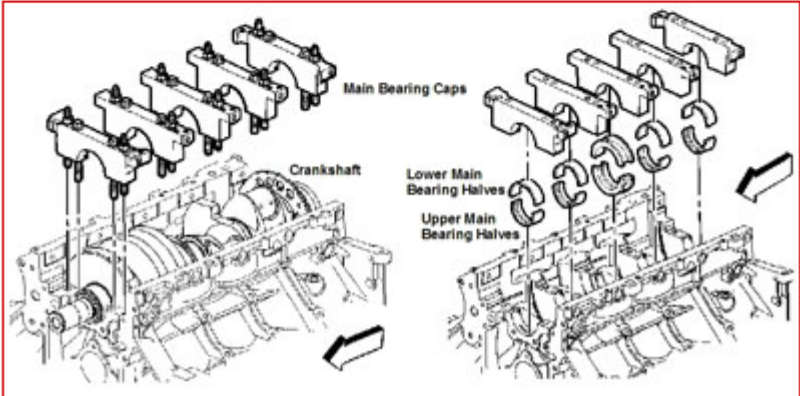
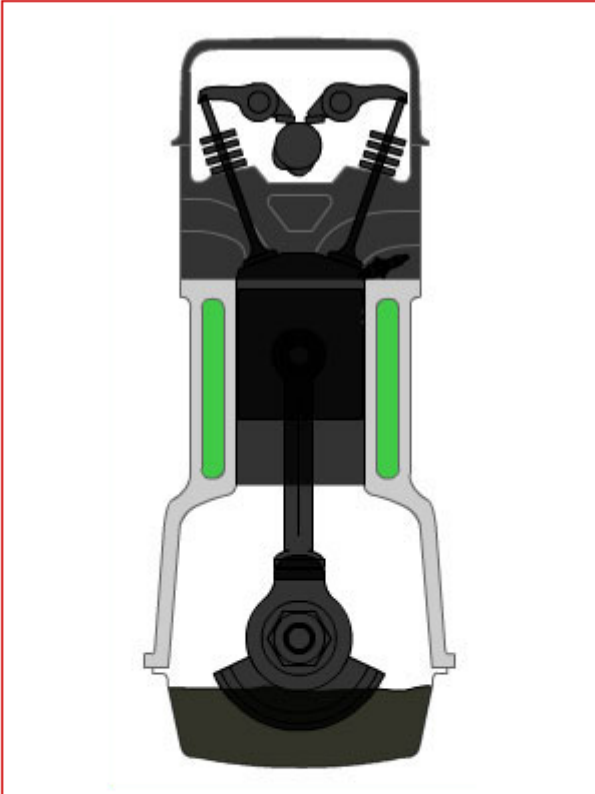

**Cylinders** – The cylinders are round holes or **bores** machined into the block for the pistons to travel up and down in.

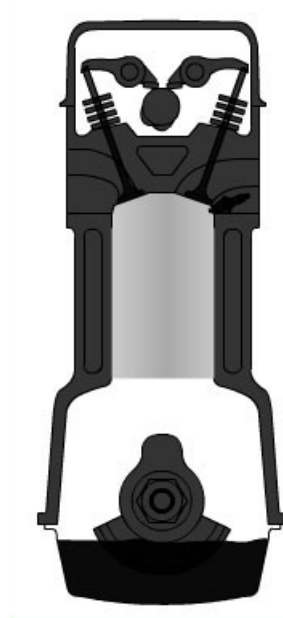

**Pistons** – Combustion pressure acts upon the tops of the pistons in the cylinders, forcing them downward. Usually made of aluminum, the pistons transmit the downward force to the connecting rods. The top of the piston's travel is called Top Dead Center (TDC) and the bottom of a piston's travel is called Bottom Dead Center (BDC).

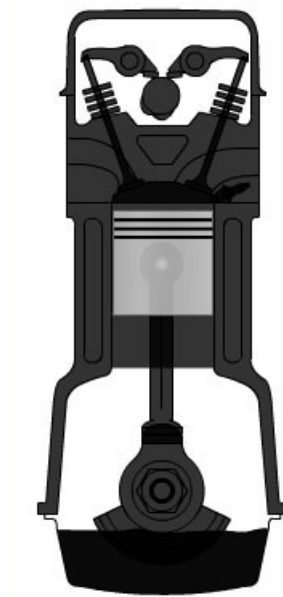

**Piston Rings** – Rings are installed in grooves around the pistons to form a seal between the piston and the cylinder wall. Two types of rings are used: **compression rings**, which prevent combustion pressure from entering the crankcase, and **oil control rings**, which prevent engine oil from entering the **combustion chamber** above the piston. Oil rings scrape excess oil from the cylinder walls for return to the crankcase.

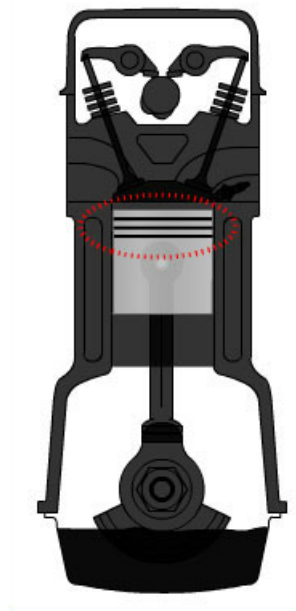

**Connecting Rods** – A rod connects each piston to the crankshaft. The small, upper end of the rod commonly has a bushing pressed into it. A **piston pin**, or **wrist pin**, attaches the piston to the rod through this bushing, which allows the rod to pivot as needed. The larger, lower end of the rod is attached to the crankshaft through **rod bearing inserts** that are stationary relative to the rod and allow the crankshaft to turn within the rod on a film of oil.

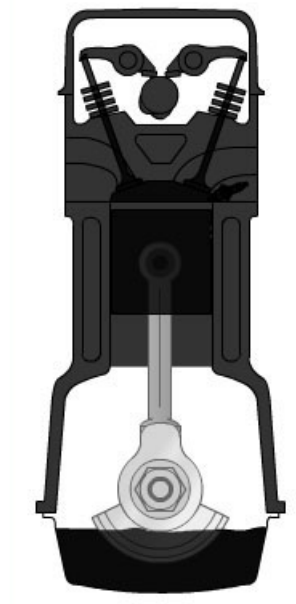

**Crankshaft** – The crankshaft is a strong, alloyed iron or steel shaft that converts the up-and-down motion of the pistons into a turning motion that can be transmitted to the drive train. The crankshaft is supported by the block in several places along its length. The crankshaft rides in **main bearings**, which are inserts similar to the rod bearings at these supports. Where the crankshaft is connected to the rods and where it is supported by the block are called **journals**. The crank is finely machined and polished at these places. The crankshaft is also drilled with a network of oil passages to deliver oil under pressure to these places from the oil galleries. **Counterweights** are formed onto the crankshaft to help prevent vibration. These weights are added to offset the weight of the piston and connecting rod assemblies. At the front of the crankshaft, outside the engine front cover, a heavy wheel containing a rubber vibration damper is installed. Also called a **harmonic balancer**, it often incorporates the crank drive belt pulley, which powers belt-driven accessories. At the rear of the crankshaft, a large **flywheel** is mounted. The flywheel can serve several purposes: a ring gear is mounted to its circumference to provide a means to start the engine. It also connects the engine to the transmission. Finally, on vehicles with manual transmissions, the flywheel is made very heavy to help smooth out power pulses from the engine (this is accomplished by the torque converter on vehicles equipped with automatic transmissions).

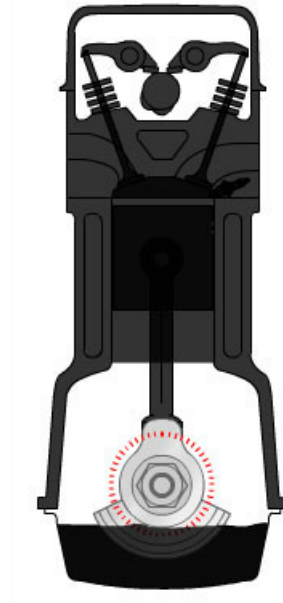

**Cylinder Head** – Like the engine block, cylinder heads are usually cast from either iron or aluminum. Most V-type, opposed, and W-type engines have two cylinder heads. Inline engines have only one cylinder head. The head bolts to the top of the block, covering and enclosing the tops of the cylinders. The head forms small pockets over the tops of the pistons called **combustion chambers**. The **spark plugs** are threaded into holes in the head and protrude into the combustion chambers (gasoline engines). **Intake ports** and **exhaust ports** are cast into the head, and small holes called **valve guides** are machined into it to position the valves. The **valves** act as gates. When open, they let air and fuel into the cylinder and exhaust gas out. When closed, they seal the pressure of compression in the combustion chamber. The valves close against machined surfaces in the combustion chamber ports called **valve seats**. On overhead cam engines like the one pictured here, the head also houses the **camshaft**. The assembly, together with other valve train components and the intake and exhaust manifolds, is referred to as the **top end**. Between the head and the block, a **head gasket** seals the combustion chambers, and water and oil passages.

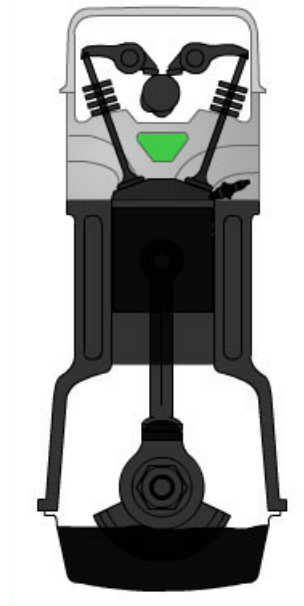

**Valve Train** – The valve train consists of the **valves**, **camshaft**, and other associated parts. The valves control the flow of the incoming air-fuel mixture and the outgoing exhaust gasses. The **intake valves** are larger than the **exhaust valves**, and many engines today have two intake and two exhaust valves per cylinder to improve efficiency and performance.

Like the crankshaft, the camshaft rides on a film of oil as it rotates on journals. Rotation of the camshaft opens the valves, and **valve springs** close them. The camshaft has carefully machined high spots called **lobes** that act upon the valves (or other parts) to open each valve at precisely the right time. As the lobe moves away, the spring closes the valve. Some engines have *dual overhead cams* (DOHC), with a cam for the intake valves and one for the exhaust valves. The engine shown here uses a *single overhead cam* (SOHC).

Engines with the camshaft located in the block are called **pushrod engines**, because long pushrods are used to transmit the camshaft's movement up to the **rocker arms**, which rock to open the valves. On these engines, the cam acts on a valve lifter, which in turn acts on a pushrod to move the rocker arm and open the valve. We will examine this arrangement later. Overhead cam engines may have a set of parts called valve followers, which operate like lifters. Some engines have a gear on the camshaft to drive the ignition distributor and oil pump, and some diesel engines and older gasoline engines have a rounded lobe on the camshaft to drive a mechanical fuel pump.

The engine top end and bottom end must be timed together so that the valves will open and close at the proper times for the positions of the pistons, and this is accomplished through the camshaft drive. The camshaft is driven by a sprocket gear mounted on the front of the crankshaft. The sprocket either meshes with a sprocket on the front of the camshaft, or, more often, the two sprockets are linked by a belt or a chain. In the engine shown here, **timing gears** and a **timing belt** are used. Both sprockets must be installed with their timing marks aligned in the proper positions in order to time the engine.

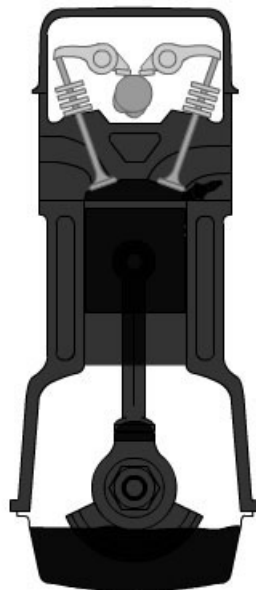

## The Four-Stroke Cycle (Otto Cycle)

A **stroke** is one movement of the piston either down from Top Dead Center (TDC) to Bottom Dead Center (BDC), or up from BDC to TDC. The term “stroke” also refers to the physical distance between these two points. One stroke of the piston moves the crankshaft through one-half of a revolution. Almost all engines on the road today operate on a cycle of four piston strokes. The strokes are the **intake stroke**, **compression stroke**, **power stroke**, and the **exhaust stroke**. This cycle turns the crankshaft through two revolutions and then the process begins again. Let’s put our simple engine into motion to see what happens in a cylinder during this four-stroke cycle. We will begin with the intake stroke.

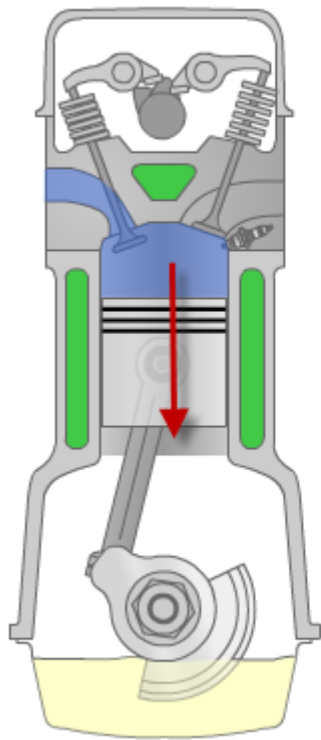

### Intake Stroke

The process begins with the intake stroke. The piston moves down from top dead center (TDC) to bottom dead center (BDC). The movement of the piston creates a partial vacuum, drawing air and fuel into the cylinder through the open intake valve. The ideal air-fuel mixture for performance, economy and emission control is 14.7 parts air to 1 part fuel. On Throttle Body fuel Injection (TBI) systems and old carbureted systems, fuel is carried in the air stream through an intake manifold and into the intake port. On Multiport Fuel Injection (MFI) systems, each cylinder has its own injector, which allows fuel to be injected into the port with more precision and uniformity than possible with Throttle Body systems. During this stroke, the exhaust valve remains closed.

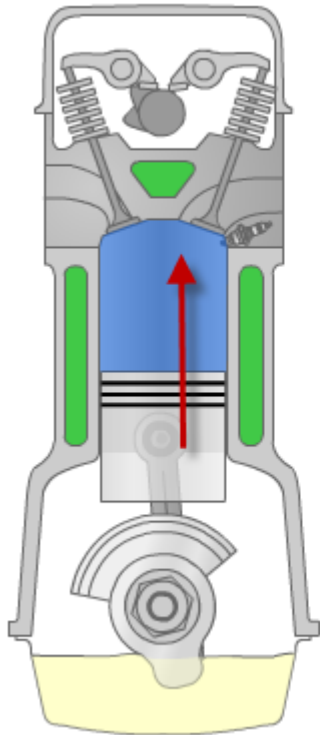

### **Compression Stroke**

After the piston passes BDC, the compression stroke begins. The intake valve closes and the mixture in the cylinder is compressed by the piston as it moves upward again to TDC. The intake and exhaust valves are both closed during this stroke, so the pressure and temperature of the air-fuel mixture rises. A typical compression ratio for a gasoline engine might be 9:1. The compression ratio is the volume of the cylinder, including the combustion chamber, with the piston at BDC compared to the volume with the piston at TDC. The crankshaft has now made one revolution.

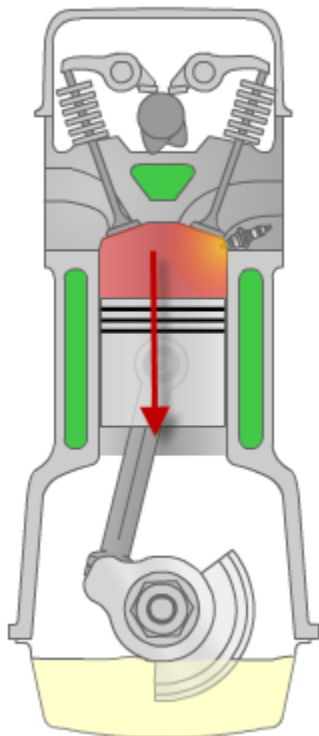

### **Power Stroke**

This is what it's all about! As the piston nears TDC with both valves closed, the compressed air-fuel mixture is ignited. Combustion occurs, resulting in a tremendous pressure increase that pushes the piston back down the cylinder. This is the power or "working" stroke. The intake and exhaust valves remain closed. In an idling engine, this happens in each cylinder about five times a second and running at 4,000 RPM it happens over 30 times a second!



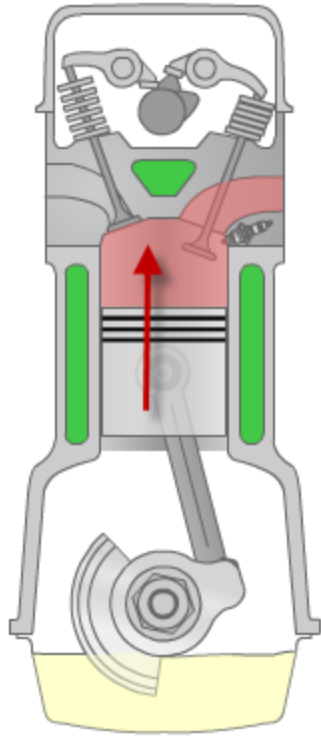

## Exhaust Stroke

Now, the spent gasses must be removed from the cylinder to make room for the next air-fuel charge. The exhaust stroke begins as the piston nears BDC. The exhaust valve opens and the piston moves upward again, pushing the burned exhaust gases out of the cylinder. The intake valve remains closed until the piston has almost reached TDC again. At this point, the engine has completed one full cycle, and the crankshaft has rotated twice. The entire process then repeats.

## Other Engine Designs

While the vast majority of automobile engines are gasoline-powered, four-stroke reciprocating piston engines, other engine designs have been developed and used in automobiles, some quite successfully. Additionally, changing economic, environmental, and political conditions have created a demand to modify or retire this proven workhorse with new or re-worked designs. As materials and technologies improve and evolve, some of these contenders may come into common use in automobiles.

### Two-Stroke Cycle Engines

A two-stroke cycle engine is another reciprocating piston design. Every downstroke delivers power in this design, and it has no valve train. Instead, in a conventional two-stroke gasoline engine, the air-fuel and exhaust gas are managed by the piston as it covers and uncovers intake and exhaust ports in the side of the cylinder. It also has no oil sump or pressurized oil delivery system, because the crankcase is part of the fuel delivery system. Instead, the crankcase is lubricated by mixing a small amount of oil with the fuel. Being able to deliver power with every down stroke and not having a heavy valve train means the two-stroke engine can provide a lot of power for its size and weight. Two-stroke engines have been used for many years in small engine applications such as outboard boat engines, motorcycles, ultralight aircraft, chainsaws and lawn equipment, etc. Some two-stroke engine automobiles have been imported to the U.S., and many medium and heavy duty diesel applications are currently equipped with two-stroke engines.

Unfortunately, the light weight and simplicity come at a price. Conventional two-stroke gasoline engines produce higher exhaust emissions and yield lower fuel economy than a comparable four-stroke engine. This is largely due to the burning of the oil in the combustion chamber and leakage of unburned fuel inherent in the engine's design. The causes of this will be clearer when we examine

the operation of the engine. Nevertheless, the two-stroke engine has received renewed interest in recent years, as innovations and advancements in fuel injection, materials, and engine management systems develop. These engines have a pressurized lubrication system, fuel injectors, and superchargers that compress the intake air, similar to a two-stroke diesel engine.

We'll begin the explanation of the two-stroke cycle with the firing of the spark plug, which occurs before every downstroke.

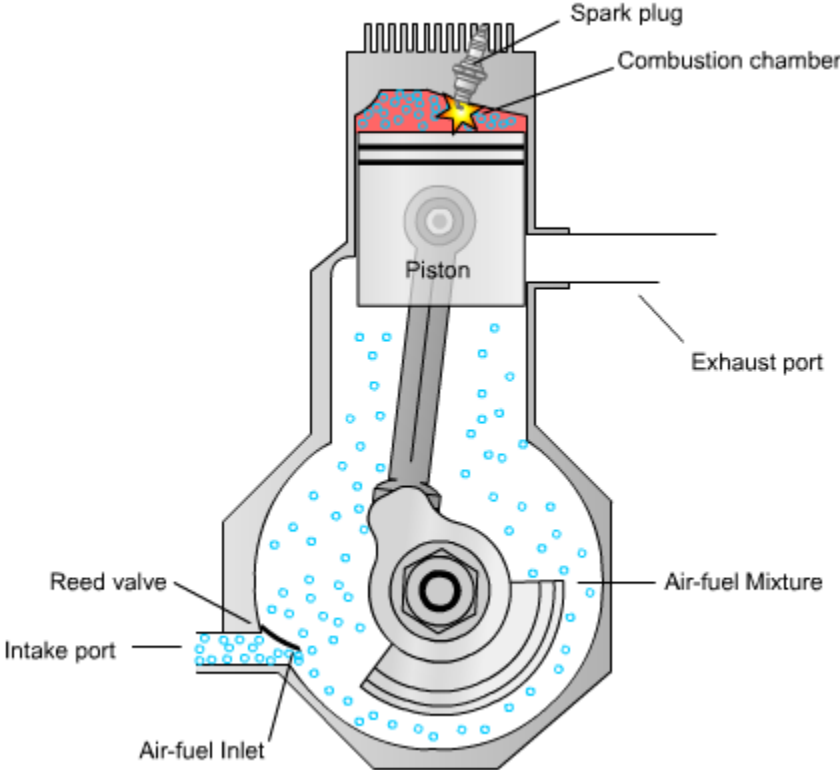

As the piston moves down, delivering power, the intake and exhaust ports are both covered. At the same time, the downward movement of the piston is pressurizing the crankcase with the next air-fuel charge, which was drawn into the crankcase through the air-fuel inlet and around the reed valve. This pressure forces the reed valve to close.

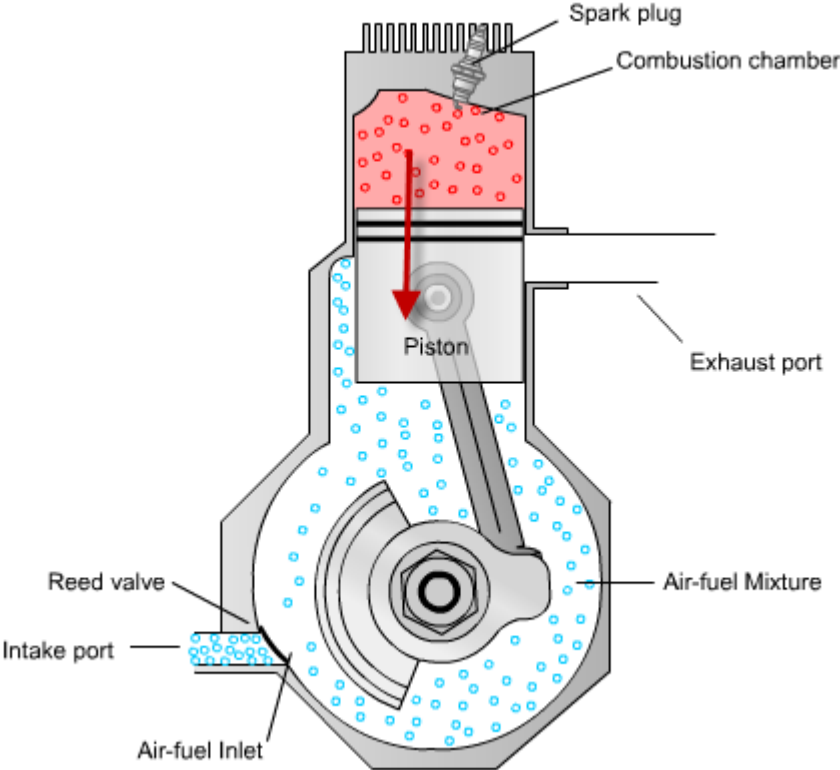

As the piston continues downward, it uncovers the exhaust port. Remaining combustion pressure begins to blow the spent gas out the port. Further downward movement uncovers the intake port as well, and both ports are open for an instant, as the pressurized air-fuel charge from the crankcase enters the cylinder. The incoming air-fuel purges the remaining exhaust gas from the cylinder. Further downward movement uncovers the intake port as well, and both ports are open for an instant, as the pressurized air-fuel charge from the crankcase enters the cylinder. The incoming air-fuel purges the remaining exhaust gas from the cylinder.

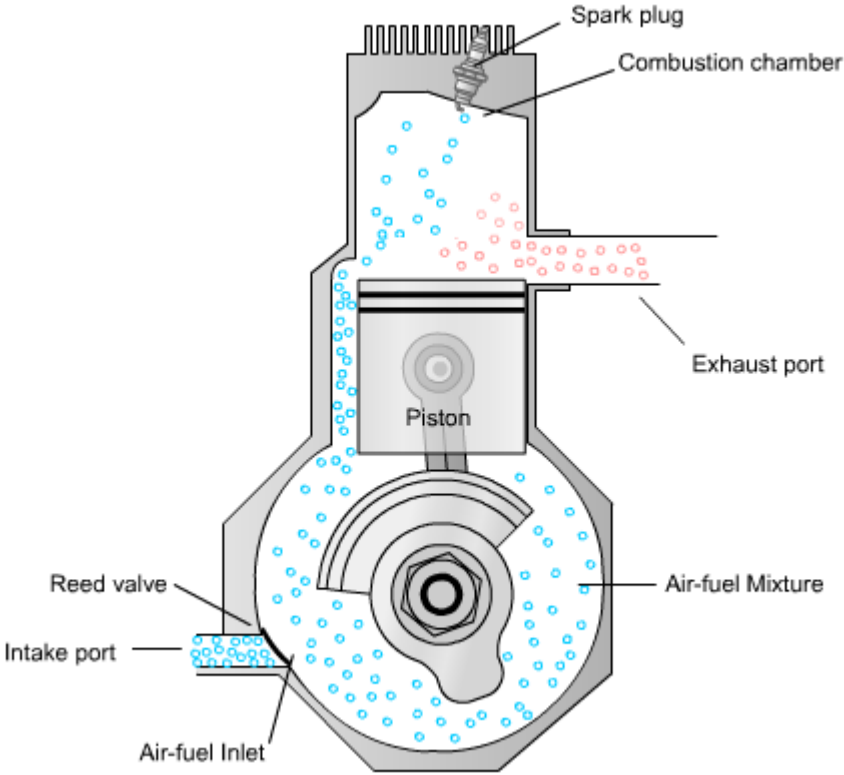

As the piston travels upward again, it covers the intake and exhaust ports so compression can begin. At the same time, the piston's movement creates a vacuum in the crankcase, opening the reed valve again and drawing in the next air-fuel charge.

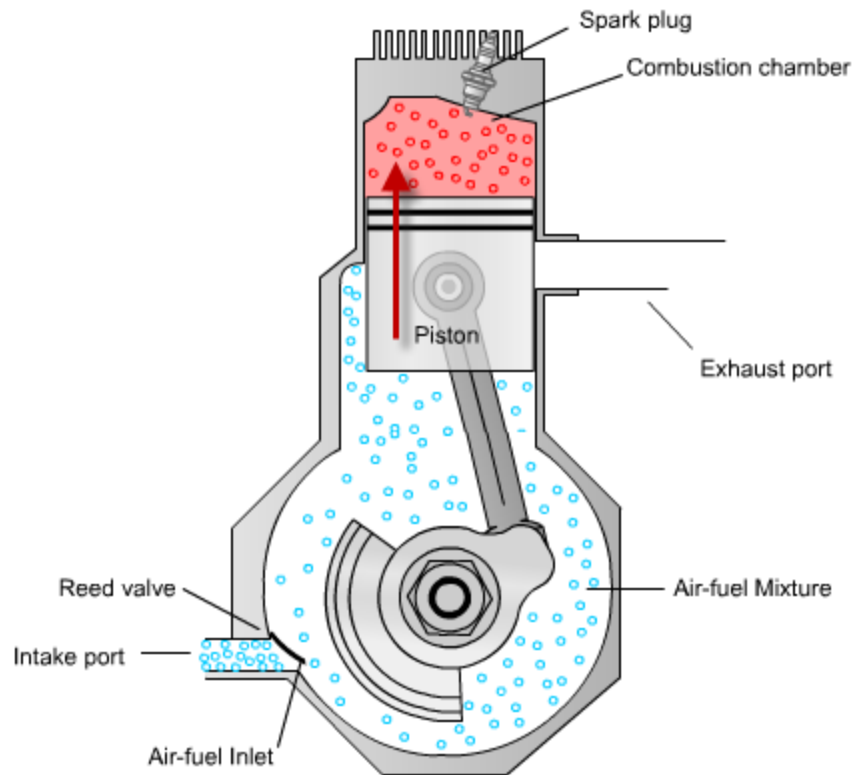

## Diesel Engines

The diesel engine is another reciprocating piston design. Diesel engines in passenger cars and light trucks operate on the four-stroke cycle, but they have important differences from the gasoline engines we have discussed. The most significant difference is the way in which diesel engines ignite the fuel. Rather than using a spark to start the combustion, a diesel engine uses the heat produced by compression of the air in the cylinder. Diesel engines must compress the air much more than a gasoline engine does – about twice as much – in order to produce enough heat to ignite the fuel. **Compression ignition** engines such as diesels must be designed heavier and stronger than **spark ignition** engines to withstand the compression and combustion produced in the cylinders. These engines have steel sleeves pressed into their cylinder bores.

All diesel engines use fuel injectors to deliver the fuel to the combustion chambers at just the right time. If the fuel were delivered along with the air, as in a gasoline engine, the fuel would ignite prematurely. The fuel pressure at the injectors must be very high to overcome the pressure in the combustion chambers created during the compression stroke. Keep in mind that with the port fuel injection systems on gasoline engines, the fuel is injected outside the combustion chamber near the intake port and drawn into the cylinder on the intake stroke.

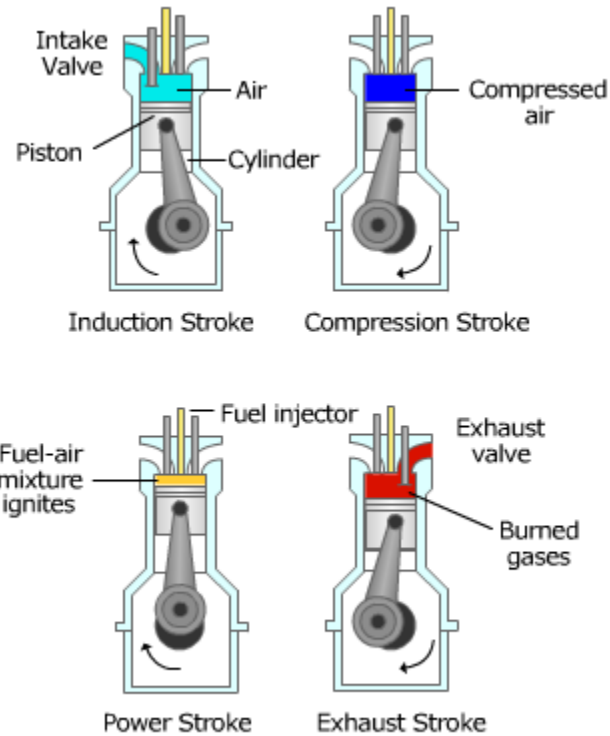

Other significant differences between gasoline and diesel powered engines are the result of differences in the fuels they burn. Diesel fuel is thicker, heavier, and less volatile than gasoline. However, there is more energy contained in a gallon of diesel fuel than in a gallon of gasoline. While a gasoline engine can produce more power by weight than a diesel engine, the diesel engine runs much leaner and provides better fuel efficiency by about one-third. This has made diesel engines attractive to automobile manufacturers at times, but these engines have other drawbacks that have prevented them from taking over in passenger cars. High exhaust emissions of particulates (soot) and oxides of nitrogen (NOX) due to the high combustion temperatures are an obstacle. Difficulty in starting diesel engines in cold weather, sluggish acceleration, smell, and noise are other factors that have prevented diesels from being widely used in automobiles, but this may change again in the future.

## Rotary Engines

The rotary engine is one of the few mass-produced automobile engines that is not a reciprocating piston design. Instead, combustion directly causes the rotation of rotors within a chamber. This design can produce a very powerful, smooth-running engine with fewer moving parts than a piston engine, and it can operate at higher RPM.

Movement of the rotor produces a low pressure area at the intake, drawing in the air-fuel mixture. Further rotor movement compresses the mixture and it is ignited.

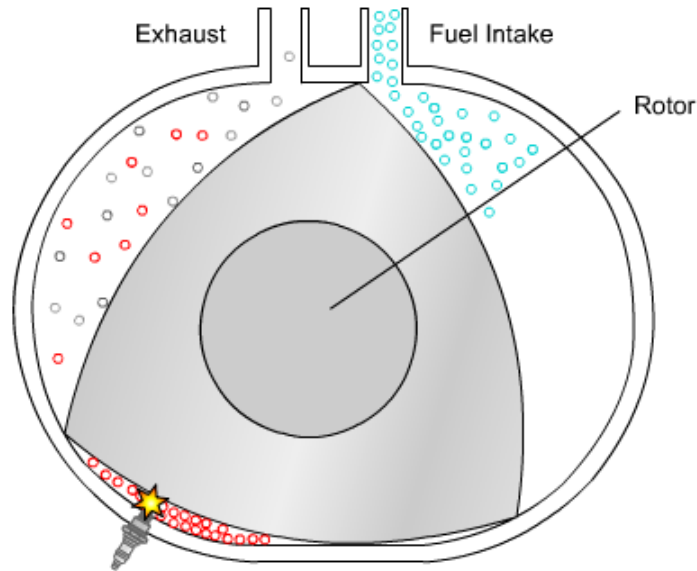

The resulting power pulse pushes on the rotor. The rotor continues turning to expel the exhaust gas. Three power pulses are produced for every revolution of the rotor.

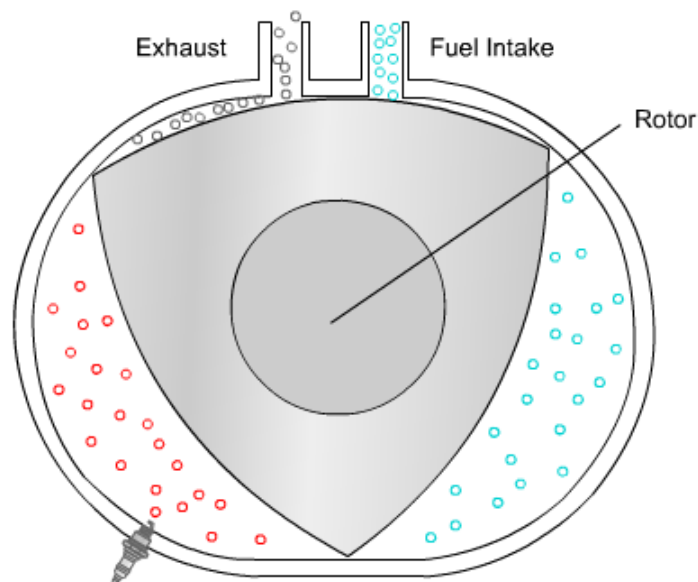

## Engine Classifications

Engines can be classified in many different ways, according to their design characteristics and operation. These differences can affect the methods of maintenance and repair. Some ways engines can be classified are:

- **Operational design** (four-stroke, two-stroke, rotary, etc.)
- **Number of cylinders** (four, five, six, eight, 12, etc.)
- **Arrangement of cylinders** (V-type, inline, etc.)
- **Displacement** (3.8 liter, 3800 cubic centimeters, 350 cubic inches, etc.)
- **Number of valves and valve train type** (overhead cam, pushrod, 24-valve, etc.)
- **Fuel type** (gasoline, diesel, propane, etc.)
- **Cooling system** (air or liquid)

We have already discussed operational design, but the other classifications may need explanation.

### Number and Arrangement of Cylinders

Automobile engines can have three, four, five, six, eight, 10, or 12 cylinders. More cylinders mean more power strokes per revolution of the crankshaft, which provides more power and smoother running. The cylinders can be arranged in a number of ways. The three most common cylinder configurations are **inline**, **V-type**, and **opposed**.

Engines with even numbers of cylinders have pairs of **companion cylinders**, in which the pistons move up and down together. When one of the pistons is on its power stroke, the other one will be on its intake stroke. Likewise, when one piston is on its exhaust stroke, its running mate will be on its compression stroke. Look for the companion cylinders in the animations here.

**Inline** engines have all their cylinders in a straight row. This is a common arrangement for four-cylinder engines and inline six-cylinder engines are still produced. Many years ago, inline eight-cylinder engines were produced, but there are several problems associated with an engine of that length.

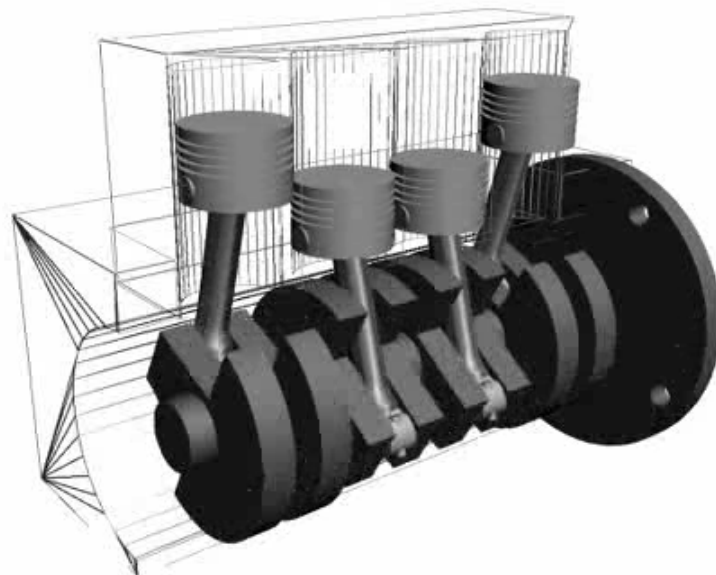



**V-type** engines have two cylinder banks, a left bank and a right bank, at an angle to one another such that when viewed from the front or rear, the block forms the shape of a “V”. As with all matters of automotive service, left and right are referenced from the vantage point of someone sitting in the vehicle. V-6 and V-8 engines are common, while a few V-10 and V-12 engines are produced. The V-6 has several advantages over inline-6 engines. The V-type is more space- and weight-efficient. Two connecting rods from opposing banks share one crank pin (rod journal).

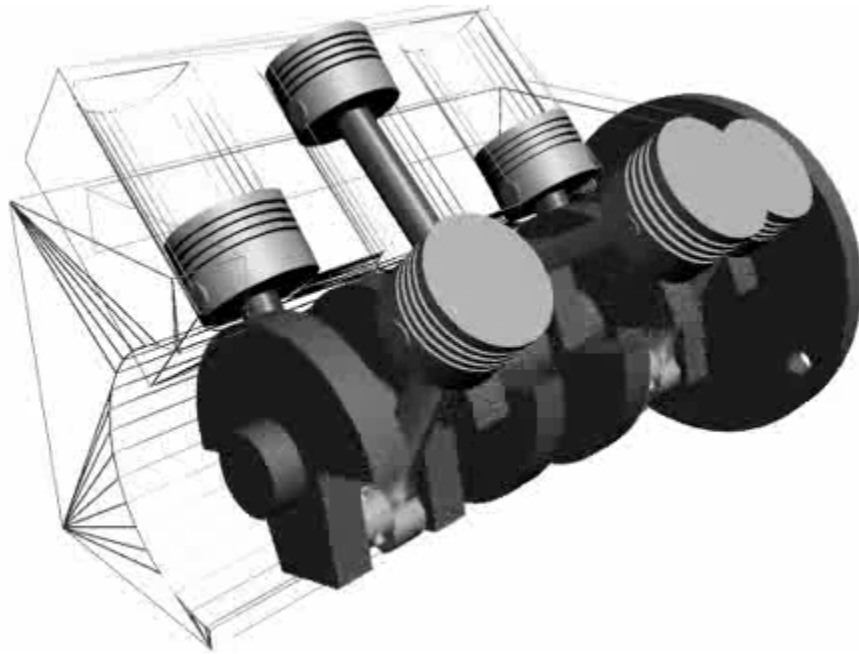

**Opposed** engines have cylinders that face each other from opposite sides of the crankshaft. This arrangement is sometimes called a boxer or pancake engine, because the cylinders lay flat, giving the engine a low profile. This makes it suitable for rear- and mid-engine applications, and this type of engine has been used in Porsches, Volkswagens (air-cooled), and Subarus.

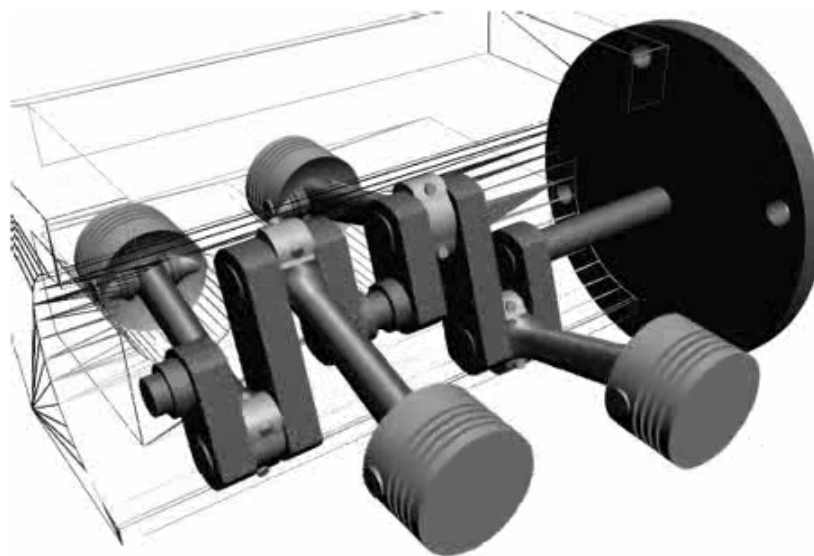

A **slant** arrangement has also been used. This arrangement is a variation on the inline design, and some manufacturers have used it to lower the hood line. It sets in the engine compartment at a slant, and may resemble “half” of a V-type engine. A few high-end automakers have produced engines with 16 cylinders in a “**W**” arrangement, but with a price of around one million dollars, you are unlikely to see one in a typical shop. The “**W**” arrangement is done to conserve space.

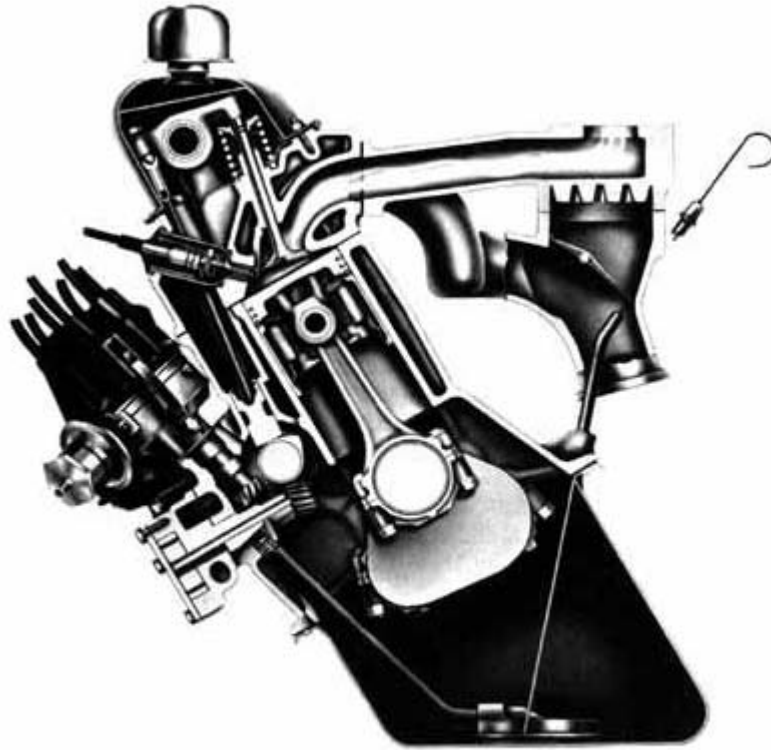

Chrysler Slant Six Engine

W-Type

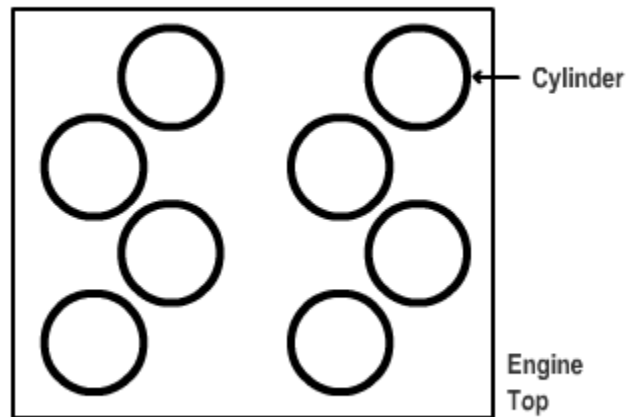
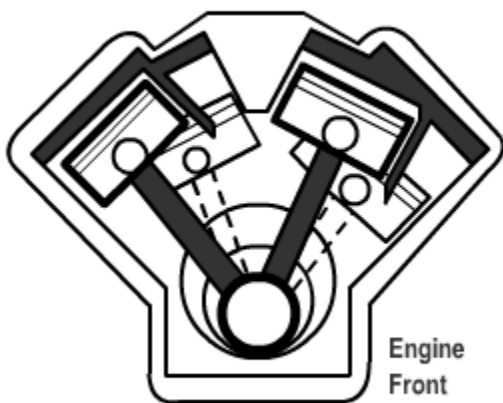

W-type Cylinder Arrangement

The cylinders are assigned numbers by the manufacturer for reference. The numbering system varies by manufacturer. Sometimes the numbers are stamped into the intake manifold. The **firing order** is the sequence in which the spark plugs fire, and is usually different from the order of the cylinder numbers. The firing order may also be stamped on the intake manifold, but both sets of numbers are available in the service information for the vehicle. The firing order will vary among manufacturers or divisions.

## **Displacement**

Commonly called “engine size,” the displacement of an engine is the volume of all the cylinders added together. In the U.S., engine displacement was expressed in cubic inches for many years. In modern vehicles, displacement is usually given in liters (L) or cubic centimeters (cc).

The diameter of the cylinder is called the **bore**. If the bore and the length of the piston stroke are known, the volume of a cylinder can be calculated. The simplest formula for calculating the volume of a cylinder is:

$$\text{Bore}^2 \times \text{Stroke} \times 0.7854 = \text{cylinder volume}$$

This result is multiplied by the number of cylinders to arrive at the displacement of the engine. The value of 0.7854 is  $\pi/4$ . Using the formula to determine the displacement of a six-cylinder engine with a bore of 10cm and a stroke of 8cm, we find:

$$100 \times 8 \times 0.7854 \times 6 = 3,769.92$$

This would be expressed as 3770cc, or approximately 3.8L.

## Number of Valves and Valve Train Type

In an earlier section, we saw the operation of an engine with a single overhead cam. We noted that a dual overhead cam (DOHC) engine has a cam for the intake valves and one for the exhaust valves. A V-type DOHC engine has four camshafts – two for each bank. Dual overhead cams are frequently used on engines that have more than two valves per cylinder. Four-cylinder engines typically have eight, 12, or 16 valves. A six-cylinder may have 12, 18, 24, or 30 valves, and a V-8 may have 16, 24, 32, or some other number of valves.



DOHC Four-Cylinder Sixteen-Valve Engine

## Pushrod Engines

Pushrod engines (those with the cam in the block) are sometimes referred to as “overhead valve” engines to differentiate them from overhead cam engines, but all modern automobile engines use overhead valves. The term was originally used to distinguish the pushrod valve arrangement from engines that have the valves in the block, a design now found only in antique cars and some small engines.

In pushrod engines, the cam acts on a valve lifter, which in turn acts on a pushrod to move the rocker arm and open the valve.

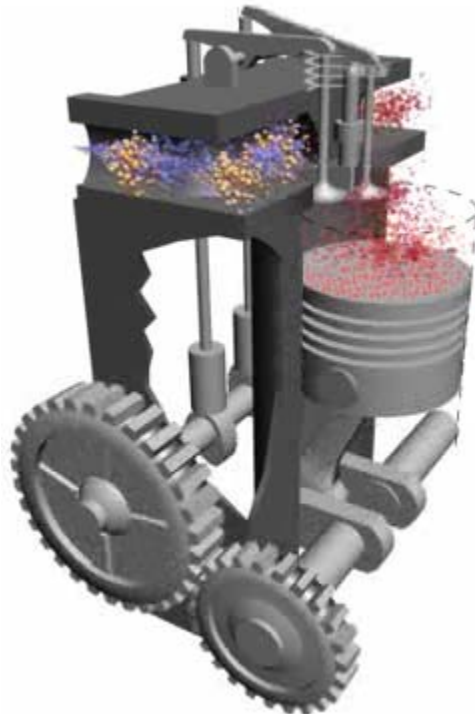

## Fuel Type

By far the most common fuels for the internal-combustion engine are gasoline and diesel fuel; however, some fleet vehicles burn alternative fuels such as natural gas, propane, or liquefied petroleum gas (LPG). These engines are usually converted gasoline or diesel engines.

## Cooling System Type

Engines are either **air-cooled** or **liquid-cooled**. Nearly all automobiles currently in production have liquid-cooled engines. Air-cooled engines can be found in motorcycles, lawn mowers, and some automobiles. Cooling fins cast on the outside of engine parts, especially the cylinders and heads, increase surface area and help dissipate heat into the air flowing around them. Air-cooled engines run at higher temperatures than liquid-cooled engines under some conditions, and they can't maintain as constant a temperature. This causes an exhaust emissions problem (especially oxides of nitrogen) that has limited their production in recent years.

In liquid-cooled engines (often called "water-cooled"), a pump circulates coolant through cavities and passages called water jackets around the cylinders and combustion chambers. A thermostat keeps the engine at the optimum operating temperature by controlling the coolant flow between the engine and the radiator, where the heat is given off to the air passing through it. The coolant is normally a mixture of 50% water and 50% antifreeze. The antifreeze provides protection against freezing, boiling, and rust and corrosion, and provides lubrication and seal conditioning for the water pump. Cooling system operation and service is covered in the Today's Class HVAC course.

From this point on, this course will deal with gasoline powered, liquid-cooled four-stroke piston engines.